



TRONÇONNAGE

ABTRENNEN

SLITTING

TRONCATURA

DARABOLÁS

TRONZADO

SELECTION OF SLITTING SAWS **242**



SLITTING SAWS **246**



MILLING ARBORS **256**



T-SLOT CUTTERS **257**

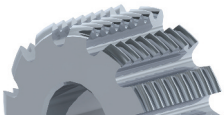

HOB CUTTERS **260**



SUPPORTING DISCS **263**



















TOOLS ON REQUEST **264**





CUTTING CONDITIONS **268**

SELECTION OF TOOLS



✓ = item from stock

		Page		<input type="checkbox"/> CARBIDE	<input checked="" type="checkbox"/> CUTINOX				
DIXI 1531 Ø 15 - 125		246	 	✓					
DIXI 1533 Ø 15 - 160		248	 	✓					
DIXI 1539 Ø 10 - 50		251		✓					
DIXI 1534 Ø 20 - 100		253	 	✓					
DIXI 1537 Ø 50 - 100		254	 		✓				
DIXI 1640 Ø 50 - 100		255		✓					

MILLING ARBORS

DIXI 2713 Ø 3 - 16		256							
DIXI 2714 Ø 5 - 16		256							

T-SLOT CUTTERS

DIXI 1525 Ø 2 - 30		257		✓	✓				
DIXI 1528 Ø 4 - 30		258		✓	✓				
DIXI 1527 Ø 4 - 16		259		✓	✓				



○ good ⊙ excellent





Steel +Pb	Low alloyed steel	High alloyed steel	DUPLEX stainless steel	Steel Hardened cast iron > 45 HRC	Cast iron	Refractory alloy	Titanium, titanium alloy	Cu alloy Silver Gold	Cu alloy difficult to machine	Al	Graphite	Plastic
⊙	⊙	⊙	○		⊙	⊙	⊙	○	○	○		○
○	○	○	○		⊙	○	○	○	○	○		○
○	○	○	○		⊙	○	○	○	○			
○	○	○	⊙		○	○	○	⊙	⊙	⊙		⊙
○	○	⊙	⊙			⊙	⊙	○	○	○		○
○	○	○	○		⊙	○	○	⊙	○	○		○

⊙	⊙	○	○		⊙	○	○	⊙	○	⊙		○
⊙	⊙	○	○		⊙	○	○	⊙	○	⊙		○
⊙	⊙	○	○		⊙	○	○	⊙	○	⊙		○

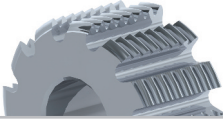
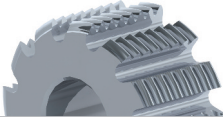
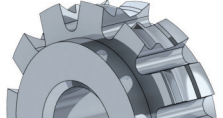
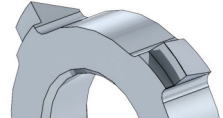

SELECTION OF SLITTING SAWS

✓ = item from stock

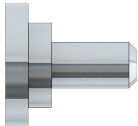
		Page	<input type="checkbox"/> CARBIDE					
HOB CUTTERS								
DIXI 1675 Ø 6 - 24		260	✓					
DIXI 1680 Ø 6 - 24		260	✓					
DIXI 1685 Ø 6 - 24		261	✓					
DIXI 1690 Ø 10 - 12		262	✓					
DIXI 1674 Ø 6 - 24		262	✓					
DIXI 1672 Ø 4 - 6		261	✓					
DIXI 1673 Ø 4 - 6		261	✓					
SUPPORTING DISCS								
DIXI 0700 DIXI 0710		263	✓					



○ good ⊙ excellent

Steel +Pb	Low alloyed steel	High alloyed steel	DUPLEX stainless steel	Steel Hardened cast iron > 45 HRC	Cast iron	Refractory alloy	Titanium, titanium alloy	Cu alloy Silver Gold	Cu alloy difficult to machine	Al	Graphite	Plastic
-----------	-------------------	--------------------	------------------------	-----------------------------------	-----------	------------------	--------------------------	----------------------	-------------------------------	----	----------	---------

⊙	⊙	○	○				○	⊙	○	⊙		
⊙	⊙	○	○				○	⊙	○	⊙		
⊙	⊙	○	○				○	⊙	○	⊙		
⊙	⊙	○	○				○	⊙	○	⊙		
⊙	⊙	○	○				○	⊙	○	⊙		
⊙	⊙	○	○				○	⊙	○	⊙		
⊙	⊙	○	○				○	⊙	○	⊙		

--	--	--	--	--	--	--	--	--	--	--	--	--



DIXI 1531

SLITTING SAWS COARSE PITCH TEETH

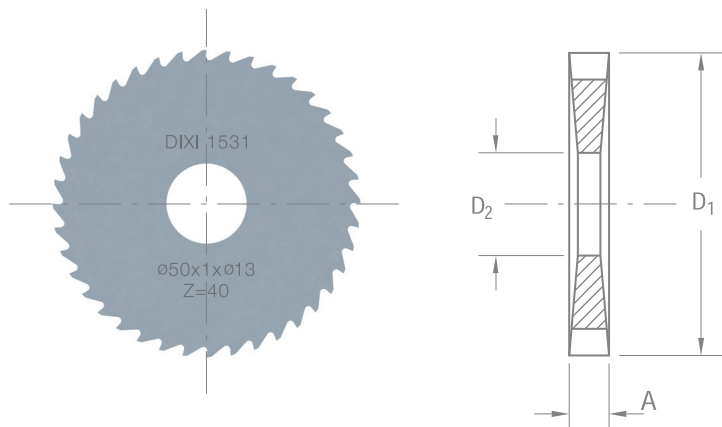

P. 268

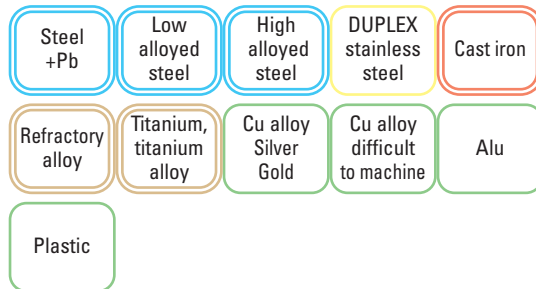

D_1 js12	$A_{\pm 0.01}$	D_2 H6	Z	CARBIDE
15	0.20	5	32	37180
15	0.30	5	24	37182
15	0.40	5	24	35382
15	0.50	5	24	35383
15	0.60	5	20	601
15	0.70	5	20	603
15	0.80	5	20	2532
15	0.90	5	20	7707
15	1.00	5	20	602
15	1.20	5	16	38947
15	1.50	5	16	38948
15	1.60	5	16	42457
15	1.80	5	16	42536
15	2.00	5	16	38949
20	0.20	5	40	35384
20	0.30	5	32	35385
20	0.40	5	32	3281
20	0.50	5	24	31481
20	0.60	5	24	604
20	0.70	5	24	605
20	0.80	5	24	37080
20	0.90	5	20	3282
20	1.00	5	20	3283
20	1.20	5	20	2425
20	1.50	5	20	3287
20	1.60	5	20	3288
20	1.80	5	20	3290
20	2.00	5	16	42458
20	2.50	5	16	42459
25	0.30	8	40	37740
25	0.40	8	32	42461
25	0.50	8	32	42376
25	0.60	8	24	42377
25	0.70	8	24	42378
25	0.80	8	24	2479
25	0.90	8	24	42379
25	1.00	8	24	42380
25	1.20	8	24	42462
25	1.50	8	20	3299
25	1.60	8	20	3300
25	1.80	8	20	3301
25	2.00	8	20	3303
25	2.50	8	20	3305

D_1 js12	$A_{\pm 0.01}$	D_2 H6	Z	CARBIDE
30	0.30	8	40	37845
30	0.40	8	40	37841
30	0.50	8	40	35386
30	0.60	8	32	30662
30	0.70	8	32	3309
30	0.80	8	32	41350
30	0.90	8	32	41351
30	1.00	8	32	36413
30	1.20	8	24	1327
30	1.50	8	24	3316
30	1.60	8	24	3317
30	1.80	8	24	3319
30	2.00	8	24	3321
30	2.50	8	20	42466
30	3.00	8	20	42467
30	4.00	8	20	42468
40	0.40	10	48	42470
40	0.50	10	40	2662
40	0.60	10	40	6348
40	0.70	10	40	17953
40	0.80	10	40	42471
40	0.90	10	32	38817
40	1.00	10	32	3034
40	1.20	10	32	3307
40	1.50	10	32	3326
40	1.60	10	32	3798
40	1.80	10	24	39499
40	2.00	10	24	42472
40	2.50	10	24	42473
40	3.00	10	24	42474
40	4.00	10	20	42475
50	0.40	13	48	26023
50	0.50	13	48	42477
50	0.60	13	48	42478
50	0.70	13	48	14681
50	0.80	13	40	3330
50	0.90	13	40	41064
50	1.00	13	40	8636
50	1.20	13	40	8637
50	1.40	13	32	3336
50	1.50	13	32	25731
50	1.60	13	32	3337
50	1.80	13	32	3657



DIXI 1531

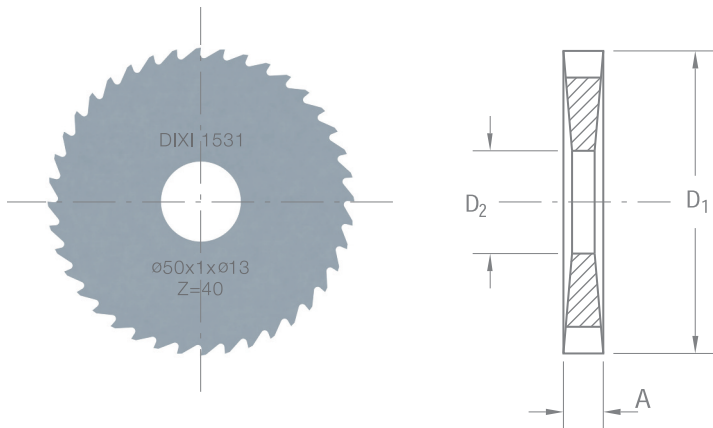

P. 268

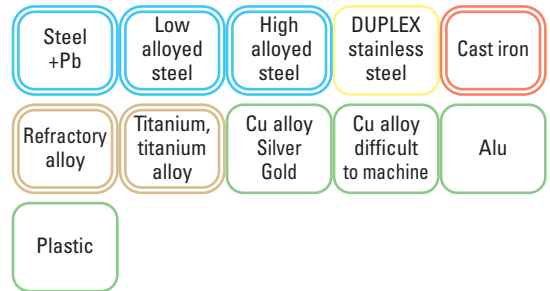

D_1 js12	$A_{\pm 0.01}$	D_2 H6	Z	CARBIDE
50	2.00	13	32	2533
50	2.50	13	32	3339
50	3.00	13	32	42479
63	0.80	16	48	3342
63	0.90	16	48	49467
63	1.00	16	48	609
63	1.20	16	40	3658
63	1.50	16	40	3345
63	1.60	16	40	3346
63	1.80	16	40	3347
63	2.00	16	40	610
63	2.50	16	32	42483
63	3.00	16	32	611
80	0.80	22	64	6070
80	0.90	22	64	49665
80	1.00	22	48	3054
80	1.20	22	48	4016
80	1.50	22	48	3349
80	1.60	22	48	34808
80	1.80	22	40	22178
80	2.00	22	40	2807
80	2.50	22	40	42484
80	3.00	22	40	21847
100	1.00	22	64	38542
100	1.20	22	64	38543
100	1.50	22	48	35387
100	1.60	22	48	39146
100	1.80	22	48	38927
100	2.00	22	48	38928
100	2.50	22	48	36588
100	3.00	22	48	38713
125	1.00	22	80	42489
125	1.20	22	64	42490
125	1.50	22	64	38480
125	1.60	22	64	42492
125	1.80	22	64	42493
125	2.00	22	64	39005



DIXI 1533

SLITTING SAWS FINE PITCH TEETH

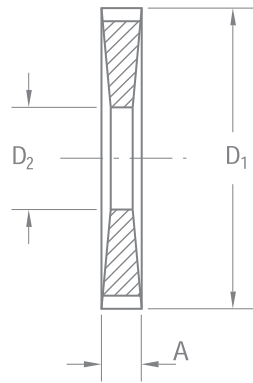
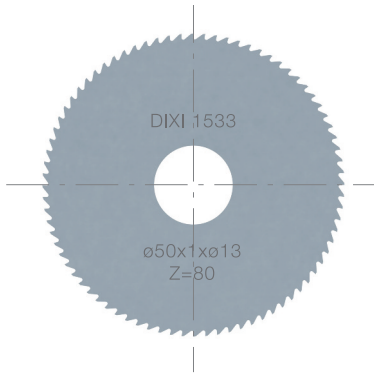

P. 268



Steel +Pb	Low alloyed steel	High alloyed steel	DUPLEX stainless steel	Cast iron
Refractory alloy	Titanium, titanium alloy	Cu alloy Silver Gold	Cu alloy difficult to machine	Alu
Plastic				

D_{1js12}	$A_{\pm 0.01}$	D_{2H6}	Z	CARBIDE
15	0.20	5	64	36382
15	0.25	5	64	35635
15	0.30	5	48	3707
15	0.40	5	48	3708
15	0.50	5	48	613
15	0.60	5	40	5453
15	0.70	5	40	6183
15	0.80	5	40	3244
15	0.90	5	40	3245
15	1.00	5	40	614
15	1.10	5	32	43250
15	1.20	5	32	37174
15	1.50	5	32	40710
15	1.60	5	32	40711
15	1.70	5	32	40712
15	1.80	5	32	40713
15	2.00	5	32	37175
20	0.20	5	80	617
20	0.25	5	64	618
20	0.30	5	64	34590
20	0.40	5	64	1659
20	0.50	5	48	18560
20	0.60	5	48	36647
20	0.70	5	48	39659
20	0.80	5	48	627
20	0.90	5	48	623
20	1.00	5	40	35565
20	1.10	5	40	2689
20	1.20	5	40	38141
20	1.30	5	40	3407
20	1.40	5	40	3408
20	1.50	5	40	624
20	1.60	5	40	3010
20	1.80	5	40	23600
20	2.00	5	32	625
20	2.50	5	32	36690
20	3.00	5	32	626
25	0.20	8	80	1660
25	0.25	8	80	3249
25	0.30	8	80	2421
25	0.35	8	80	1688

D_{1js12}	$A_{\pm 0.01}$	D_{2H6}	Z	CARBIDE
25	0.40	8	64	37661
25	0.50	8	64	14254
25	0.60	8	64	630
25	0.70	8	64	36365
25	0.80	8	48	632
25	0.90	8	48	633
25	1.00	8	48	634
25	1.10	8	48	2422
25	1.20	8	48	3250
25	1.30	8	48	3410
25	1.40	8	48	3412
25	1.50	8	40	35450
25	1.60	8	40	3413
25	1.80	8	40	3414
25	2.00	8	40	636
25	2.50	8	40	637
25	3.00	8	32	38971
25	4.00	8	32	3728
30	0.20	8	100	14689
30	0.25	8	100	4262
30	0.30	8	80	638
30	0.40	8	80	639
30	0.50	8	80	18429
30	0.60	8	64	18375
30	0.70	8	64	37731
30	0.80	8	64	35516
30	0.90	8	64	36052
30	1.00	8	64	2376
30	1.10	8	48	35420
30	1.20	8	48	36384
30	1.30	8	48	3417
30	1.40	8	48	2424
30	1.50	8	48	2924
30	1.60	8	48	3418
30	1.70	8	48	5948
30	1.80	8	48	6362
30	2.00	8	48	645
30	2.50	8	40	6361
30	3.00	8	40	3419
30	4.00	8	40	33482
30	5.00	8	32	35095



DIXI 1533



P. 268

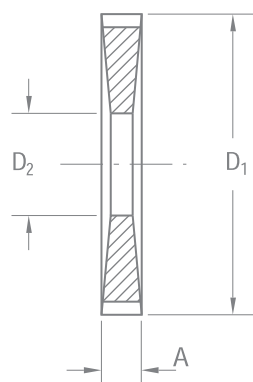
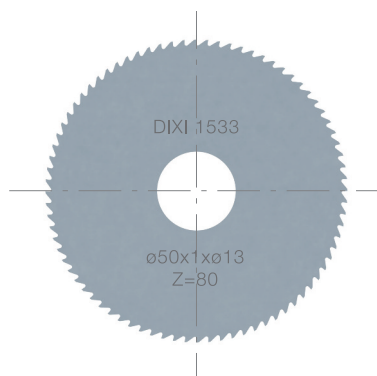

Steel +Pb	Low alloyed steel	High alloyed steel	DUPLEX stainless steel	Cast iron
Refractory alloy	Titanium, titanium alloy	Cu alloy Silver Gold	Cu alloy difficult to machine	Alu
Plastic				

D_1 js12	$A_{\pm 0.01}$	D_2 H6	Z	CARBIDE
40	0.20	10	128	24084
40	0.25	10	100	22049
40	0.30	10	100	35370
40	0.40	10	100	4690
40	0.50	10	80	648
40	0.60	10	80	677
40	0.70	10	80	649
40	0.80	10	80	35444
40	0.90	10	80	35369
40	1.00	10	64	653
40	1.10	10	64	3253
40	1.20	10	64	36049
40	1.30	10	64	43352
40	1.40	10	64	3422
40	1.50	10	64	36050
40	1.60	10	64	36051
40	1.70	10	64	6170
40	1.80	10	64	3424
40	2.00	10	48	656
40	2.50	10	48	36648
40	3.00	10	48	658
40	4.00	10	40	3737
40	5.00	10	40	35097
50	0.20	13	128	36385
50	0.25	13	128	3426
50	0.30	13	128	659
50	0.40	13	100	35234
50	0.50	13	100	31880
50	0.60	13	100	3030
50	0.70	13	100	2957
50	0.80	13	80	661
50	0.90	13	80	3255
50	1.00	13	80	662
50	1.10	13	80	1663
50	1.20	13	80	2536
50	1.30	13	80	3429
50	1.40	13	80	43114
50	1.50	13	64	37517
50	1.60	13	64	663
50	1.70	13	64	8001
50	1.80	13	64	36336
50	2.00	13	64	37806

D_1 js12	$A_{\pm 0.01}$	D_2 H6	Z	CARBIDE
50	2.50	13	64	37732
50	3.00	13	48	35636
50	4.00	13	48	667
50	5.00	13	48	35109
63	0.30	16	128	5398
63	0.40	16	128	669
63	0.50	16	128	2969
63	0.60	16	100	2634
63	0.70	16	100	3207
63	0.80	16	100	36739
63	0.90	16	100	36386
63	1.00	16	100	671
63	1.20	16	80	35233
63	1.40	16	80	5093
63	1.50	16	80	2774
63	1.60	16	80	676
63	1.70	16	80	3432
63	1.80	16	80	3433
63	2.00	16	80	672
63	2.50	16	64	673
63	3.00	16	64	674
63	4.00	16	64	3748
63	5.00	16	48	31882
80	0.80	22	128	35817
80	0.90	22	128	46466
80	1.00	22	100	679
80	1.20	22	100	680
80	1.50	22	100	35721
80	1.60	22	100	19241
80	1.80	22	100	14115
80	2.00	22	80	17745
80	2.50	22	80	4030
80	3.00	22	80	684
80	4.00	22	80	21256
80	5.00	22	80	35122



DIXI 1533

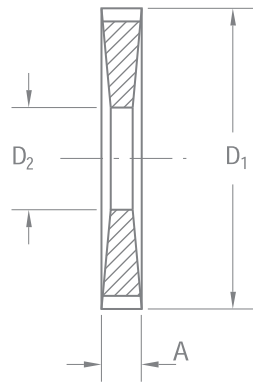
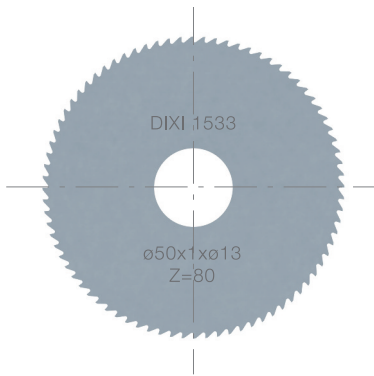

P. 268

Steel +Pb	Low alloyed steel	High alloyed steel	DUPLEX stainless steel	Cast iron
Refractory alloy	Titanium, titanium alloy	Cu alloy Silver Gold	Cu alloy difficult to machine	Alu
Plastic				

D_1 js12	A ±0.01	D_2 H6	Z	CARBIDE
100	0.80	22	128	685
100	1.00	22	128	35816
100	1.20	22	128	38383
100	1.50	22	100	36363
100	1.60	22	100	3438
100	1.80	22	100	6057
100	2.00	22	100	36048
100	2.50	22	100	689
100	3.00	22	80	36364
100	4.00	22	80	35138
100	5.00	22	80	35136
125	1.00	22	160	30687
125	1.20	22	128	35141
125	1.50	22	128	34954
125	2.00	22	128	34827
125	3.00	22	100	35294
160	1.20	32	160	34523
160	1.50	32	160	35299



DIXI 1539

SLITTING SAWS EXTRA FINE TEETH

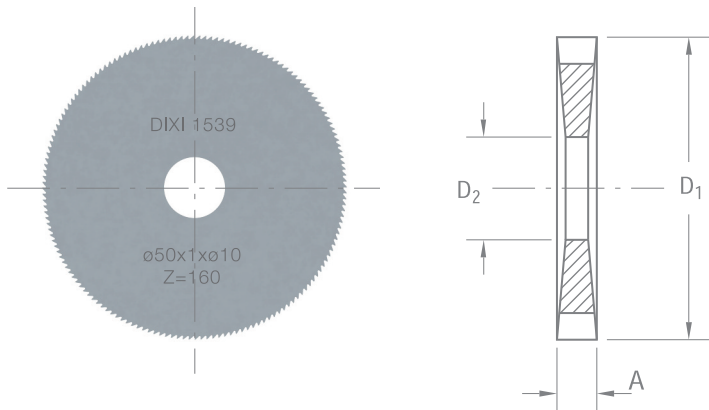

P. 270



Steel +Pb	Low alloyed steel	High alloyed steel	DUPLEX stainless steel	Cast iron
Refractory alloy	Titanium, titanium alloy	Cu alloy Silver Gold	Cu alloy difficult to machine	

$D_1 \pm 0.03$	$A \pm 0.005$	$D_2 H6$	Z	CARBIDE
10	0.10	3	60	964494
10	0.11	3	60	964499
10	0.12	3	60	964500
10	0.13	3	60	964501
10	0.14	3	60	964502
10	0.15	3	60	964503
10	0.16	3	60	964504
10	0.17	3	60	964505
10	0.18	3	60	964506
10	0.19	3	60	964507
10	0.20	3	60	964508
10	0.22	3	60	965568
10	0.24	3	60	963179
15	0.08	5	80	45005
15	0.10	5	80	40599
15	0.11	5	80	57238
15	0.12	5	80	23559
15	0.13	5	80	46325
15	0.14	5	80	38354
15	0.15	5	80	40588
15	0.16	5	80	28784
15	0.17	5	80	57240
15	0.18	5	80	27224
15	0.19	5	80	46858
15	0.20	5	80	19385
15	0.21	5	80	66021
15	0.22	5	80	60191
15	0.23	5	80	58358
15	0.24	5	80	950356
15	0.25	5	80	19823
15	0.30	5	80	26517
15	0.35	5	80	40299
15	0.40	5	80	19825
15	0.50	5	80	19826
15	0.60	5	80	40300
15	0.70	5	80	40301
15	0.80	5	80	40302
15	0.90	5	80	40303
15	1.00	5	80	26518
15	1.10	5	80	40304
15	1.20	5	80	40305
15	1.40	5	80	40306
15	1.50	5	80	33843

$D_1 \pm 0.03$	$A \pm 0.005$	$D_2 H6$	Z	CARBIDE
20	0.12	5	100	40314
20	0.14	5	100	40307
20	0.15	5	100	43684
20	0.16	5	100	4913
20	0.18	5	100	16032
20	0.20	5	100	4914
20	0.25	5	100	28665
20	0.30	5	100	28340
20	0.35	5	100	40317
20	0.40	5	100	38355
20	0.50	5	100	35628
20	0.60	5	100	40320
20	0.70	5	100	40322
20	0.80	5	100	40324
20	0.90	5	100	40326
20	1.00	5	100	40328
20	1.10	5	100	40330
20	1.20	5	100	40332
20	1.40	5	100	40334
20	1.50	5	100	40336
20	0.12	6	100	40315
20	0.14	6	100	40308
20	0.16	6	100	40309
20	0.18	6	100	40310
20	0.20	6	100	40311
20	0.25	6	100	40312
20	0.30	6	100	40313
20	0.35	6	100	40316
20	0.40	6	100	40318
20	0.50	6	100	40319
20	0.60	6	100	40321
20	0.70	6	100	40323
20	0.80	6	100	40325
20	0.90	6	100	40327
20	1.00	6	100	40329
20	1.10	6	100	40331
20	1.20	6	100	40333
20	1.40	6	100	40335
20	1.50	6	100	40337





P. 270

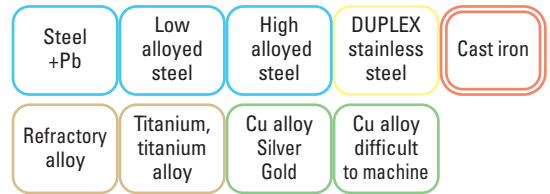
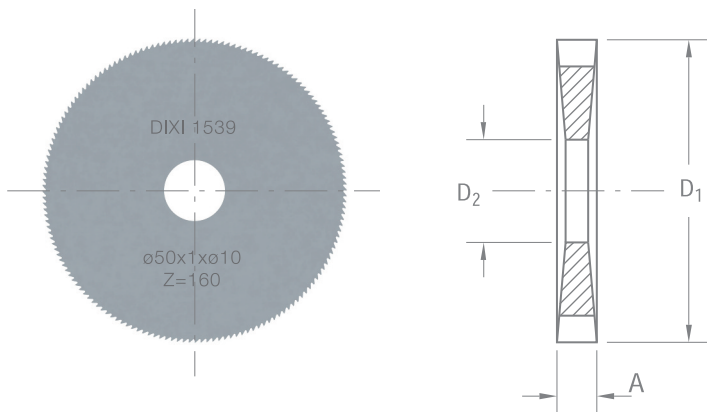

D_1 js10	$A_{\pm 0.01}$	D_2 H6	Z	CARBIDE
25	0.20	6	120	3649
25	0.25	6	120	40339
25	0.30	6	120	40341
25	0.35	6	120	40343
25	0.40	6	120	40345
25	0.50	6	120	40347
25	0.60	6	120	40349
25	0.70	6	120	40351
25	0.80	6	120	40353
25	0.90	6	120	40355
25	1.00	6	120	40357
25	1.10	6	120	40359
25	1.20	6	120	40361
25	1.40	6	120	40363
25	1.50	6	120	40365
25	0.20	8	120	40338
25	0.25	8	120	40340
25	0.30	8	120	40342
25	0.35	8	120	40344
25	0.40	8	120	40346
25	0.50	8	120	40348
25	0.60	8	120	40350
25	0.70	8	120	40352
25	0.80	8	120	40354
25	0.90	8	120	40356
25	1.00	8	120	40358
25	1.10	8	120	40360
25	1.20	8	120	40362
25	1.40	8	120	40364
25	1.50	8	120	40366
30	0.30	8	128	40367
30	0.35	8	128	40368
30	0.40	8	128	40369
30	0.50	8	128	40370
30	0.60	8	128	40371
30	0.70	8	128	40372
30	0.80	8	128	40373
30	0.90	8	128	40374
30	1.00	8	128	40375
30	1.10	8	128	40376
30	1.20	8	128	40377
30	1.40	8	128	40378
30	1.50	8	128	40379

D_1 js10	$A_{\pm 0.01}$	D_2 H6	Z	CARBIDE
40	0.30	8	160	40393
40	0.35	8	160	40395
40	0.40	8	160	40397
40	0.50	8	160	40399
40	0.60	8	160	40401
40	0.70	8	160	40403
40	0.80	8	160	40405
40	0.90	8	160	40407
40	1.00	8	160	40409
40	1.20	8	160	40413
40	1.40	8	160	40415
40	1.50	8	160	40417
40	0.30	10	160	40394
40	0.35	10	160	40396
40	0.40	10	160	40398
40	0.50	10	160	40400
40	0.60	10	160	40402
40	0.70	10	160	40404
40	0.80	10	160	40406
40	0.90	10	160	40408
40	1.00	10	160	40410
40	1.10	10	160	40412
40	1.20	10	160	40414
40	1.50	10	160	40418
50	0.30	10	160	40445
50	0.40	10	160	40447
50	0.50	10	160	40448
50	0.60	10	160	40449
50	0.70	10	160	40450
50	0.80	10	160	40451
50	0.90	10	160	40452
50	1.00	10	160	40453
50	1.20	10	160	40455
50	1.50	10	160	40457

DIXI 1534

SLITTING SAWS HELLER PITCH TEETH

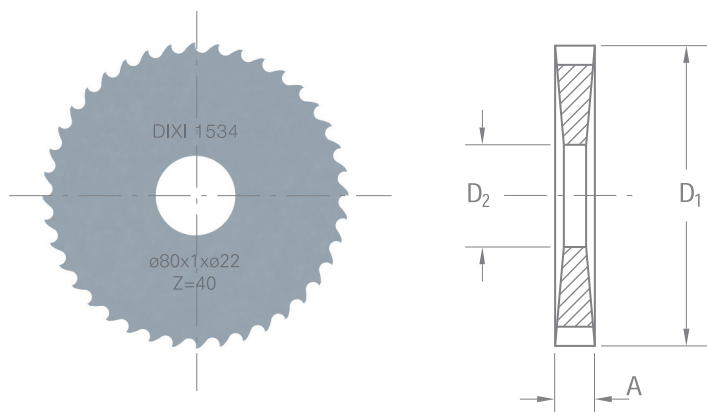

P. 268



Steel +Pb	Low alloyed steel	High alloyed steel	DUPLEX stainless steel	Cast iron
Refractory alloy	Titanium, titanium alloy	Cu alloy Silver Gold	Cu alloy difficult to machine	Alu
Plastic				

D ₁ js12	A ±0.01	D ₂ H6	Z	CARBIDE
20	0.30	5	32	34869
20	0.50	5	24	29836
20	0.60	5	24	29541
20	0.70	5	24	29282
20	0.80	5	24	31598
20	1.00	5	20	39176
20	1.20	5	20	42582
20	1.50	5	20	31267
20	2.00	5	16	39550
25	0.30	8	40	29785
25	0.50	8	32	42427
25	0.60	8	32	42428
25	0.80	8	24	29542
25	0.90	8	24	42430
25	1.00	8	24	30411
25	1.30	8	24	42431
25	1.50	8	20	38204
30	0.30	8	40	42434
30	0.40	8	40	42435
30	0.50	8	40	28826
30	0.60	8	32	3308
30	0.80	8	32	38804
30	1.00	8	32	38806
30	1.20	8	24	36576
30	1.30	8	24	38114
30	1.50	8	24	36577
30	1.60	8	24	38756
30	2.00	8	24	35379
40	0.50	10	40	34152
40	0.80	10	40	29793
40	1.00	10	32	32137
40	2.00	10	24	35310
50	0.50	13	48	14901
50	0.80	13	40	29704
50	1.00	13	40	5111
50	1.50	13	40	39153
50	2.00	13	32	37281

D ₁ js12	A ±0.01	D ₂ H6	Z	CARBIDE
63	0.40	16	64	34999
63	0.50	16	64	2872
63	0.60	16	48	37364
63	0.80	16	48	29794
63	1.00	16	48	28979
63	1.30	16	40	40597
63	1.50	16	40	28990
63	1.60	16	40	41638
63	1.80	16	40	37787
63	2.00	16	40	28845
63	2.50	16	32	35380
63	3.00	16	32	28828
80	0.80	22	64	36043
80	1.00	22	48	29219
80	1.20	22	48	35967
80	1.50	22	48	18568
80	2.00	22	40	28829
100	0.80	22	64	35381
100	1.00	22	64	35429
100	1.20	22	64	35431
100	1.50	22	48	25267
100	1.60	22	48	25335
100	2.00	22	48	29408



DIXI 1537 CUTINOX

SLITTING SAWS FOR STAINLESS STEEL

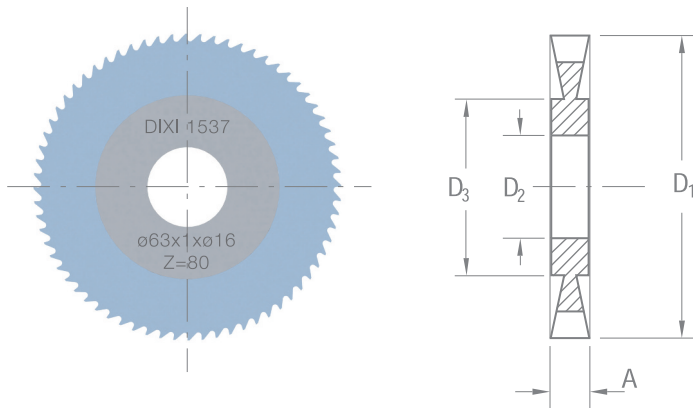

P. 272

Steel +Pb	Low alloyed steel	High alloyed steel	DUPLEX stainless steel	Refractory alloy
Titanium, titanium alloy	Cu alloy Silver Gold	Cu alloy difficult to machine	Alu	Plastic

D_{1js12}	$A_{\pm 0.01}$	D_3	D_{2H6}	Z	CUTINOX
50	0.80	30	13	68	954330
50	1.00	30	13	68	954331
63	0.60	40	16	80	60407
63	0.80	40	16	80	60408
63	1.00	40	16	80	60409
80	0.60	50	22	100	60410
80	0.80	50	22	100	60411
80	1.00	50	22	100	60414
100	0.80	60	22	120	60412
100	1.00	60	22	120	60413



DIXI 1640 R + L

PARTING OFF SLITTING SAWS LEFT AND RIGHT HAND CUTTING

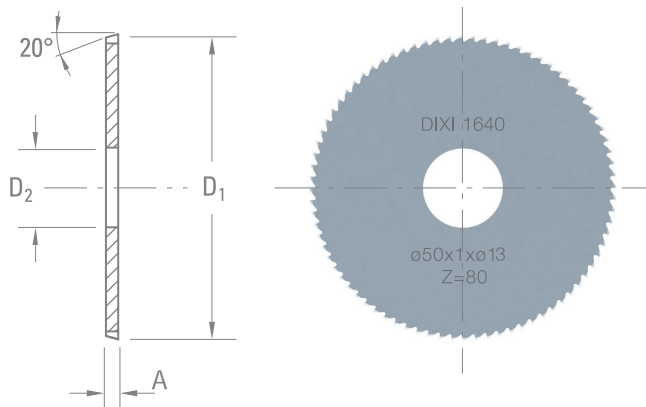

P. 268

Steel +Pb	Low alloyed steel	High alloyed steel	DUPLEX stainless steel	Cast iron
Refractory alloy	Titanium, titanium alloy	Cu alloy Silver Gold	Cu alloy difficult to machine	Alu
Plastic				

DIXI 1640 L

D_1 js12	$A_{\pm 0.01}$	D_2 H6	Z	CARBIDE	CUTINOX
50	0.50	13	100	977529	977548
50	0.80	13	80	977530	957215
50	1.00	13	80	977531	977549
63	0.50	16	128	977532	977552
63	0.80	16	100	954255	977553
63	1.00	16	100	977533	955787
80	0.80	22	128	975393	975569
80	1.00	22	100	977534	977554
100	0.80	22	100	977535	977555
100	1.00	22	100	977536	977556

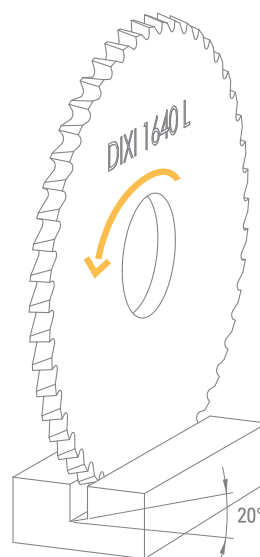

DIXI 1640 R

D_1 js12	$A_{\pm 0.01}$	D_2 H6	Z	CARBIDE	CUTINOX
50	0.50	13	100	977520	977537
50	0.80	13	80	977521	977538
50	1.00	13	80	59024	977539
63	0.50	16	128	977522	977540
63	0.80	16	100	977523	977541
63	1.00	16	100	977524	977542
80	0.80	22	128	977525	977543
80	1.00	22	100	977526	977544
100	0.80	22	100	977527	977545
100	1.00	22	100	977528	977547

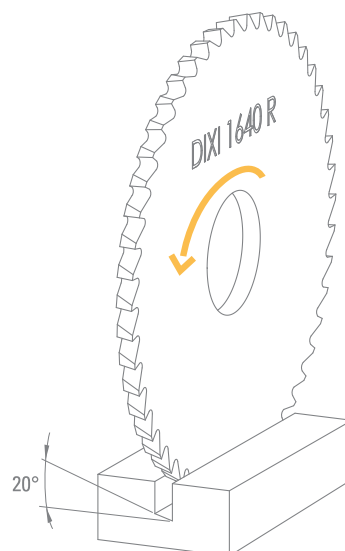

DIXI 2713

MILLING ARBORS WITH FRONT CLAMPING

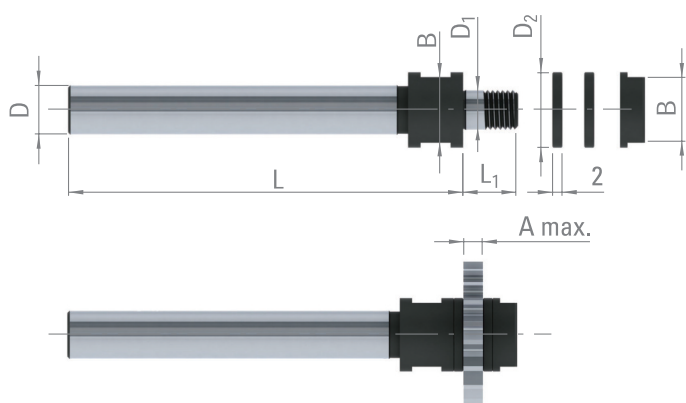

$D_{1\ h6}$	D_{h6}	D_2	L	L_1	B	$A_{\max.}$	Art.
3.00	5	5	60	7.0	4	3	968329
5.00	6	10	70	10.0	8	6	953911
5.00	10	10	80	10.0	8	6	953917
6.00	10	12	80	10.5	10	6	953918
8.00	10	15	80	10.0	13	6	954975
8.00	12	15	90	11.0	13	6	953919
10.00	10	18	80	10.5	15	6	954976
10.00	16	18	100	11.5	15	6	953920
13.00	16	22	110	12.0	19	6	953921
16.00	20	26	120	13.0	22	6	953922

DIXI 2714

MILLING ARBORS WITH REAR CLAMPING

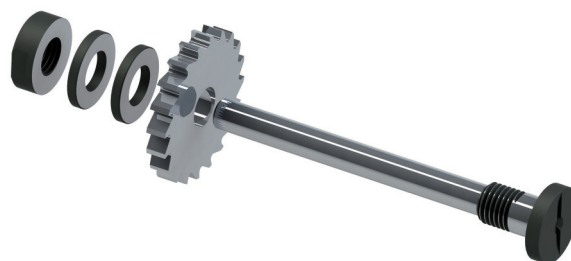
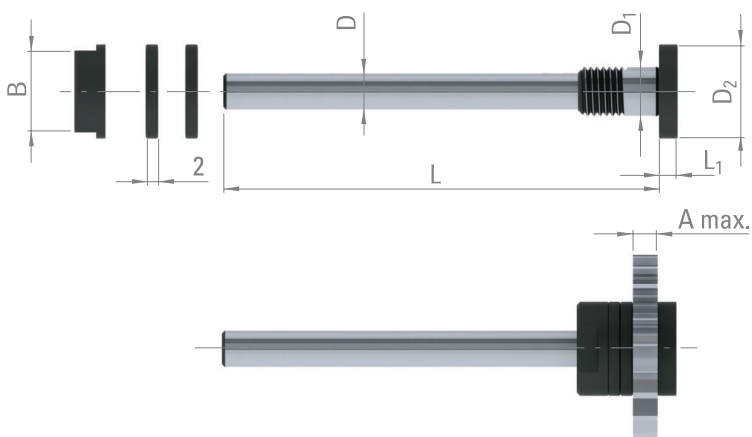

$D_{1\ h6}$	D_{h6}	D_2	L	L_1	B	$A_{\max.}$	Art.
5.00	4	10	50	3.0	8	6	953923
6.00	5	12	60	3.0	10	6	953924
8.00	6	15	70	3.0	13	6	953925
8.00	7	15	80	3.0	13	6	953926
10.00	6	18	70	3.5	15	6	953927
10.00	8	18	90	3.5	15	6	953928
13.00	10	22	110	3.5	19	6	953929
16.00	12	26	120	3.5	22	6	953930



T-SLOT CUTTERS
STRAIGHT FLUTE



P. 274

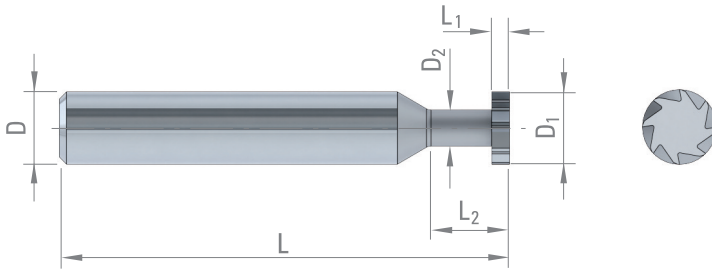

Steel +Pb	Low alloyed steel	High alloyed steel	DUPLEX stainless steel	Cast iron
Refractory alloy	Titanium, titanium alloy	Cu alloy Silver Gold	Cu alloy difficult to machine	Alu
Plastic				

D ₁ ∅ < 4.0 ±0.01 ∅ ≥ 4.0 -0.05/-0.10	L ₁	D ₂ 0/-0.20	L ₂ ±0.2	D _{h5}	L	Z	CARBIDE	CUTINOX
2.0	0.2 - 1.0	1.0	3.0	4	42	3 - 6	<input type="checkbox"/>	<input checked="" type="checkbox"/>
3.0	0.2 - 1.5	1.5	3.5	4	42	3 - 6	<input type="checkbox"/>	<input checked="" type="checkbox"/>
4.0	0.2 - 1.5	2.5	6.0	4	42	3 - 6	<input type="checkbox"/>	<input checked="" type="checkbox"/>
5.0	0.5 - 1.5	3.0	6.0	5	42	3 - 6	<input type="checkbox"/>	<input checked="" type="checkbox"/>
6.0	0.5 - 2.5	3.5	7.0	6	42	4 - 8	<input type="checkbox"/>	<input checked="" type="checkbox"/>
8.0	0.5 - 3.0	4.0	9.0	8	50	5 - 10	<input type="checkbox"/>	<input checked="" type="checkbox"/>
10.0	0.5 - 4.0	5.0	9.0	10	50	5 - 12	<input type="checkbox"/>	<input checked="" type="checkbox"/>
12.0	0.5 - 3.5	5.0	11.5	6	50	6 - 16	<input type="checkbox"/>	<input checked="" type="checkbox"/>
12.0	0.5 - 4.0	6.0	14.0	10	50	6 - 16	<input type="checkbox"/>	<input checked="" type="checkbox"/>
15.0	0.5 - 5.0	8.0	14.0	10	60	8 - 18	<input type="checkbox"/>	<input checked="" type="checkbox"/>
16.0	0.5 - 2.9	8.0	14.0	10	60	8 - 20	<input type="checkbox"/>	<input checked="" type="checkbox"/>
16.0	3.0 - 6.0	8.0	14.0	10	60	8 - 20	<input type="checkbox"/>	<input checked="" type="checkbox"/>
18.0	0.5 - 2.9	8.0	14.0	10	60	10 - 24	<input type="checkbox"/>	<input checked="" type="checkbox"/>
18.0	3.0 - 6.0	8.0	14.0	10	60	10 - 24	<input type="checkbox"/>	<input checked="" type="checkbox"/>
20.0	0.5 - 2.9	8.0	11.0	10	60	10 - 24	<input type="checkbox"/>	<input checked="" type="checkbox"/>
20.0	3.0 - 6.0	8.0	14.0	10	60	10 - 24	<input type="checkbox"/>	<input checked="" type="checkbox"/>
25.0	0.5 - 3.9	8.0	13.0	10	60	10 - 32	<input type="checkbox"/>	<input checked="" type="checkbox"/>
25.0	4.0 - 8.0	8.0	18.0	10	60	10 - 32	<input type="checkbox"/>	<input checked="" type="checkbox"/>
30.0	0.5 - 3.9	8.0	13.0	10	60	10 - 36	<input type="checkbox"/>	<input checked="" type="checkbox"/>
30.0	4.0 - 8.0	8.0	18.0	10	60	10 - 36	<input type="checkbox"/>	<input checked="" type="checkbox"/>

Half finished product, available from stock and adaptable to your needs.

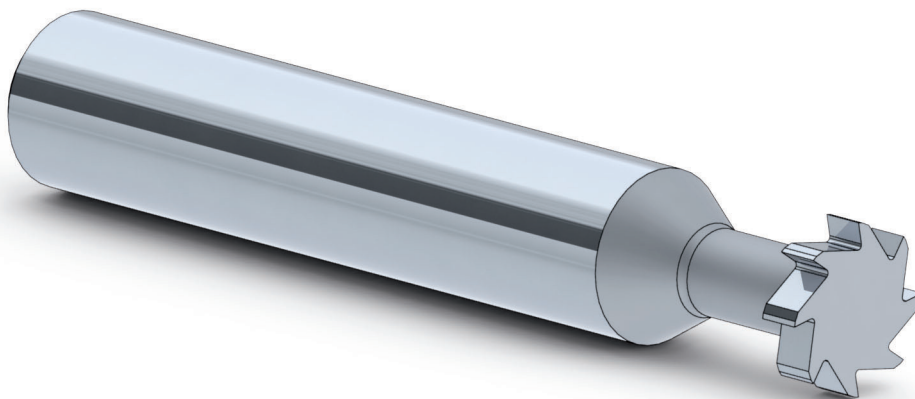

T-SLOT CUTTERS
STAGGERED TOOTH



P. 274

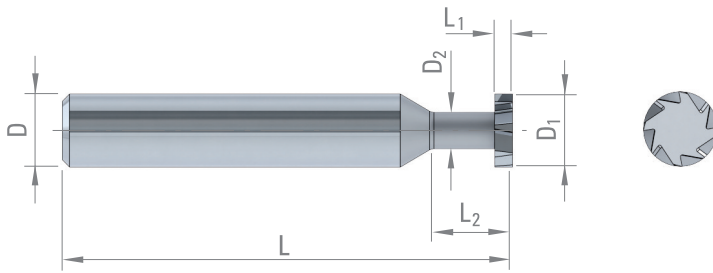

Steel +Pb	Low alloyed steel	High alloyed steel	DUPLEX stainless steel	Cast iron
Refractory alloy	Titanium, titanium alloy	Cu alloy Silver Gold	Cu alloy difficult to machine	Alu
Plastic				

D ₁ ∅ < 4.0 ±0.01 ∅ ≥ 4.0 -0.05/-0.10	L ₁	D ₂ 0/-0.20	L ₂ ±0.2	D _{h5}	L	Z	CARBIDE	CUTINOX
4.0	0.5 - 3.0	2.5	6.0	4	42	4 - 6	☐	■
5.0	0.5 - 3.0	3.0	6.0	5	42	4 - 6	☐	■
6.0	0.5 - 3.0	3.5	7.0	6	42	4 - 6	☐	■
8.0	1.0 - 4.0	4.0	9.0	8	50	4 - 8	☐	■
10.0	1.0 - 4.0	5.0	9.0	10	50	6 - 10	☐	■
12.0	0.5 - 3.5	5.0	11.5	6	50	6 - 10	☐	■
12.0	1.0 - 5.0	6.0	14.0	10	50	6 - 10	☐	■
15.0	1.5 - 6.0	8.0	14.0	10	60	8 - 14	☐	■
16.0	1.5 - 3.9	8.0	14.0	10	60	8 - 14	☐	■
16.0	4.0 - 6.0	8.0	14.0	10	60	8 - 14	☐	■
18.0	1.5 - 3.9	8.0	14.0	10	60	10 - 16	☐	■
18.0	4.0 - 6.0	8.0	14.0	10	60	10 - 16	☐	■
20.0	1.5 - 3.9	8.0	11.0	10	60	10 - 18	☐	■
20.0	4.0 - 6.0	8.0	14.0	10	60	10 - 18	☐	■
25.0	1.5 - 4.9	8.0	13.0	10	60	10 - 24	☐	■
25.0	5.0 - 10.0	8.0	18.0	10	60	14 - 24	☐	■
30.0	1.5 - 4.9	8.0	13.0	10	60	18 - 28	☐	■
30.0	5.0 - 10.0	8.0	18.0	10	60	18 - 28	☐	■

Half finished product, available from stock and adaptable to your needs.

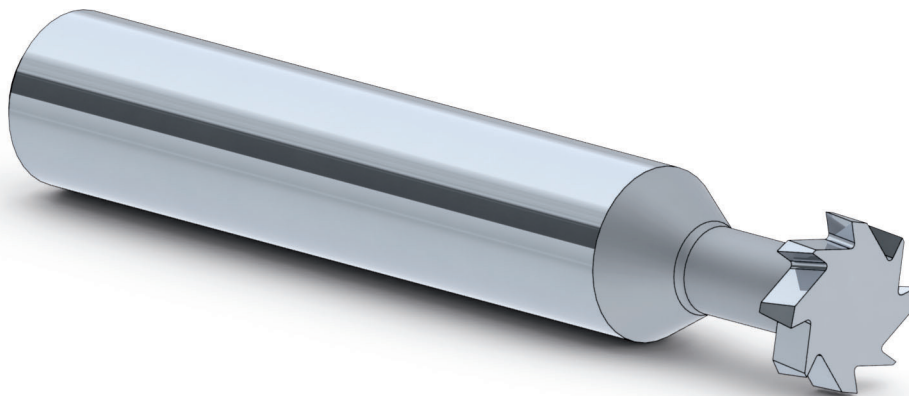

T-SLOT CUTTERS
FULL RADIUS



P. 274

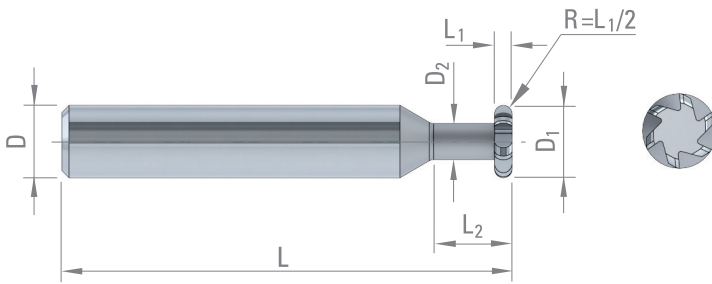

Steel +Pb	Low alloyed steel	High alloyed steel	DUPLEX stainless steel	Cast iron
Refractory alloy	Titanium, titanium alloy	Cu alloy Silver Gold	Cu alloy difficult to machine	Alu
Plastic				

D ₁ ∅ < 4.0 ±0.03 ∅ ≥ 4.0 -0.05/-0.10	L ₁	D ₂ 0/-0.20	L ₂ ±0.2	D _{h5}	L	Z	CARBIDE	CUTINOX
4.0	0.4 - 1.5	1.5	6.0	4	42	4	<input type="checkbox"/>	<input checked="" type="checkbox"/>
6.0	0.5 - 2.0	3.5	7.0	6	42	6	<input type="checkbox"/>	<input checked="" type="checkbox"/>
8.0	1.0 - 3.0	4.0	9.0	8	50	6	<input type="checkbox"/>	<input checked="" type="checkbox"/>
10.0	1.0 - 4.0	5.0	9.0	10	50	8	<input type="checkbox"/>	<input checked="" type="checkbox"/>
12.0	0.5 - 3.5	5.0	11.5	6	50	10	<input type="checkbox"/>	<input checked="" type="checkbox"/>
12.0	1.0 - 5.0	6.0	14.0	10	50	10	<input type="checkbox"/>	<input checked="" type="checkbox"/>
16.0	1.0 - 6.0	8.0	14.0	10	60	12	<input type="checkbox"/>	<input checked="" type="checkbox"/>

Half finished product, available from stock and adaptable to your needs.

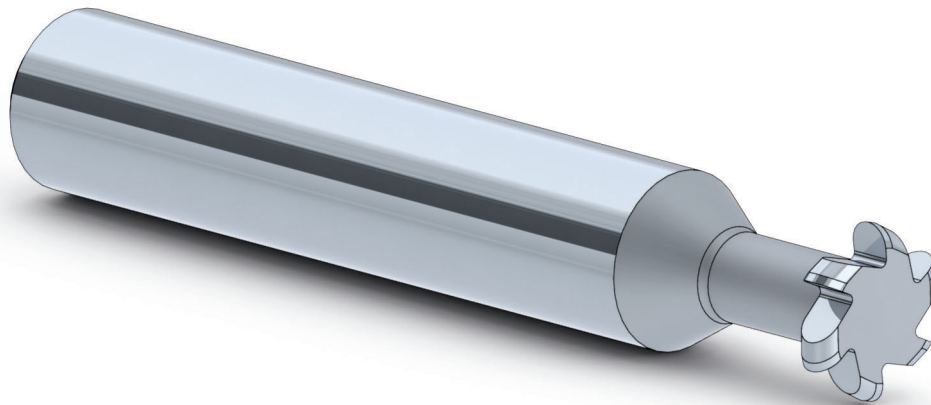

Other tooth shapes see page 275



HOB CUTTERS
EPICYCLIC AND INVOLUTE PROFILE

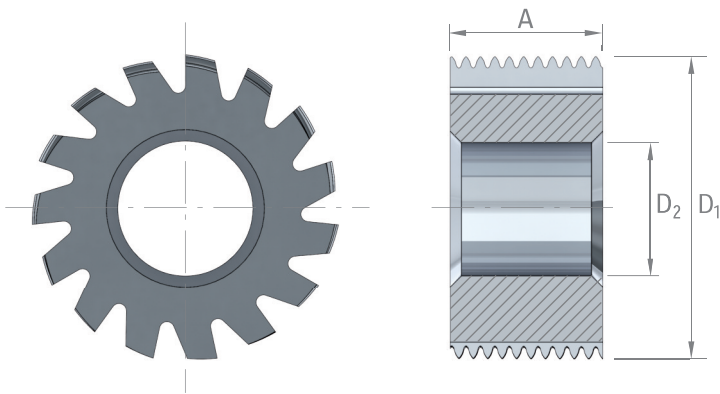

- Steel +Pb
- Low alloyed steel
- High alloyed steel
- DUPLEX stainless steel
- Titanium, titanium alloy
- Cu alloy
Silver
Gold
- Cu alloy difficult to machine
- Alu

D ₁	A	D _{2H3}	Z	CARBIDE
6	4	3.5	12	□
	5	3.5	12	□
	6	3.5	12	□
8	4	3.5	15	□
	5	3.5	12	□
10	6	3.5	12	□
	4	3.5	15	□
	5	3.5	12	□
	6	3.5	12	□
	6	4.5	12	□
12	6	4.5	15	□
	6	4.5	12	□
	6	4.5	15	□
	6	5.0	12	□
	6	5.0	15	□
	6	6.0	12	□
	6	6.0	15	□
	8	4.5	15	□
	8	5.0	15	□
	8	6.0	15	□
16	10	8.0	12	□
	6	8.0	12	□
	6	8.0	15	□
	8	8.0	12	□
	8	8.0	15	□
	10	8.0	12	□
18	10	8.0	15	□
	10	8.0	12	□
	12	8.0	12	□
	12	8.0	15	□
	6	6.0	12	□
	6	8.0	12	□
	6	8.0	15	□
24	8	8.0	12	□
	8	8.0	15	□
	10	8.0	12	□
	10	8.0	15	□
	12	8.0	12	□
	12	8.0	15	□
	16	8.0	12	□
	16	8.0	15	□
	16	10.0	12	□

Module (m) = 0.04 - 1.00

DIXI 1675
Epicyclic



DIXI 1680
Involute

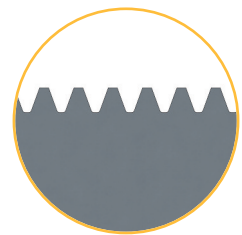

Regrindable
logarithmic relief

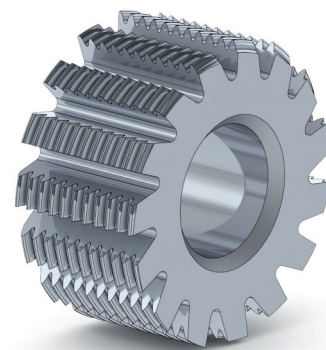
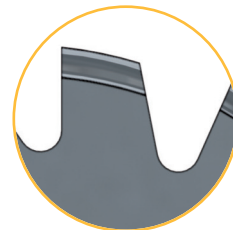

Coatings on request



DIXI 1685 TOOLS ON REQUEST

HOB CUTTERS FOR INDEX

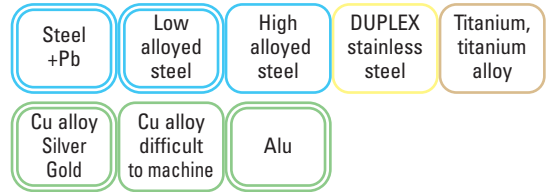
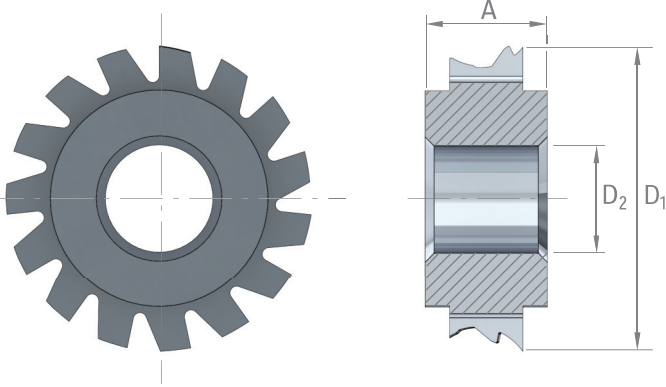

D ₁	A	D _{2H3}	Z	CARBIDE
6	4	3.5	12	<input type="checkbox"/>
6	5	3.5	12	<input type="checkbox"/>
6	6	3.5	12	<input type="checkbox"/>
8	5	3.5	12	<input type="checkbox"/>
8	6	3.5	12	<input type="checkbox"/>
10	5	3.5	12	<input type="checkbox"/>
10	6	3.5	12	<input type="checkbox"/>
10	6	4.5	12	<input type="checkbox"/>
12	6	4.5	12	<input type="checkbox"/>
12	6	5.0	12	<input type="checkbox"/>
12	6	6.0	12	<input type="checkbox"/>
16	6	8.0	12	<input type="checkbox"/>
16	8	8.0	12	<input type="checkbox"/>
16	10	8.0	12	<input type="checkbox"/>
18	6	6.0	12	<input type="checkbox"/>
18	8	8.0	12	<input type="checkbox"/>
18	10	8.0	12	<input type="checkbox"/>
24	6	8.0	12	<input type="checkbox"/>
24	8	8.0	12	<input type="checkbox"/>
24	10	8.0	12	<input type="checkbox"/>
24	12	8.0	12	<input type="checkbox"/>

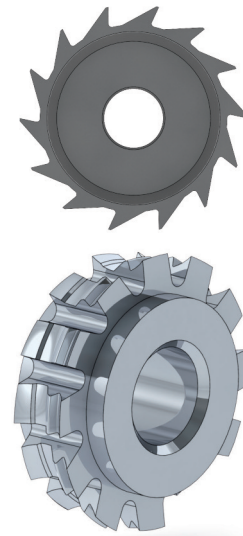

Coatings on request

DIXI 1672 - 1673 TOOLS ON REQUEST

HOB CUTTERS

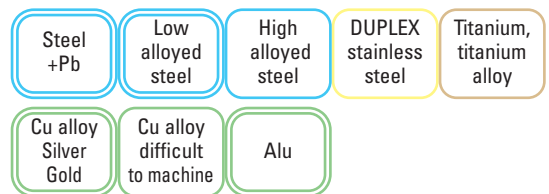

D ₁	L ₁	D ₂	L ₂	D _{h5}	L	Z	CARBIDE
4.0	4.0	2.4	4.0	4	40	6-10	<input type="checkbox"/>
5.0	4.0	3.0	4.0	5	40	6-10	<input type="checkbox"/>
5.0	4.0	4.0	4.0	6	40	6-10	<input type="checkbox"/>
6.0	4.0	4.0	4.0	6	40	6-10	<input type="checkbox"/>

D ₁	L ₁	D ₂	L ₂	D _{h5}	L	Z	CARBIDE
4.0	2.0	2.4	4.0	4	40	5	<input type="checkbox"/>
5.0	2.0	3.0	4.0	5	40	6	<input type="checkbox"/>
5.0	2.0	4.0	4.0	6	40	6	<input type="checkbox"/>
6.0	2.0	4.0	4.0	6	40	6	<input type="checkbox"/>

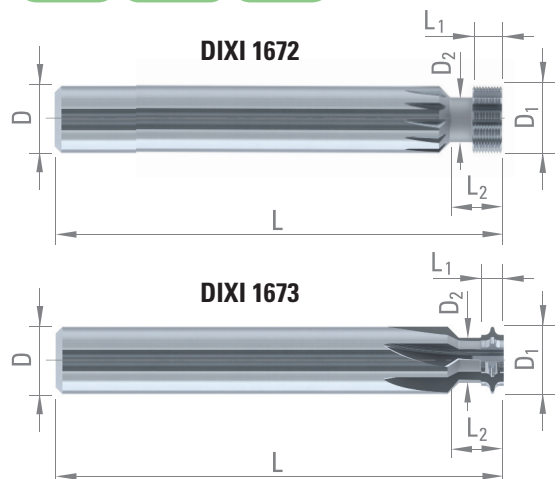

DIXI 1690 TOOLS ON REQUEST

HOB CUTTERS FRONTAL GEAR CUTTING

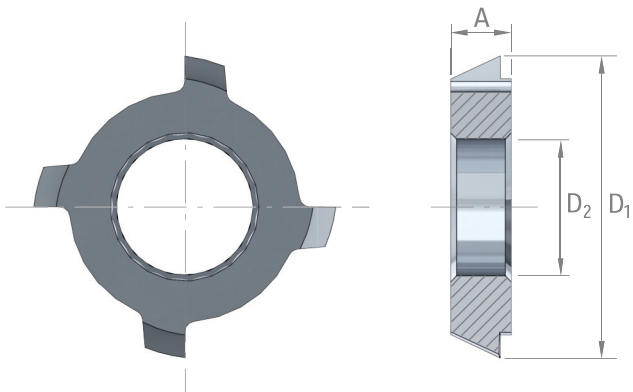

D ₁	A	D _{2 H3}	Z	CARBIDE
10	2	4.5	4	<input type="checkbox"/>
10	2	4.5	5	<input type="checkbox"/>
10	2	4.5	6	<input type="checkbox"/>
12	2	4.5	2	<input type="checkbox"/>
12	2	4.5	3	<input type="checkbox"/>
12	2	4.5	4	<input type="checkbox"/>
12	2	4.5	5	<input type="checkbox"/>
12	2	4.5	6	<input type="checkbox"/>

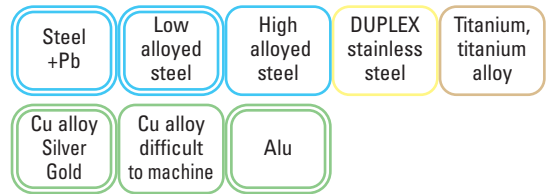

Module (m) = 0.03 - 1.00

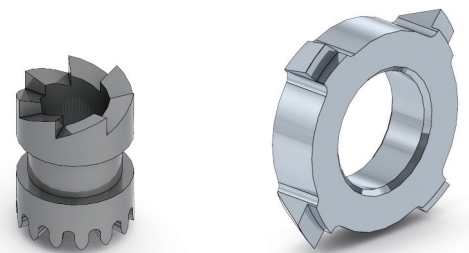

Coatings on request

DIXI 1674 TOOLS ON REQUEST

MODULE CUTTERS TOOTH PER TOOTH CUTTING

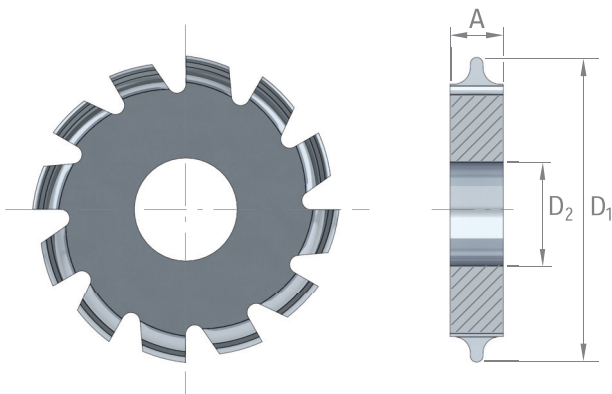

D ₁	A	D _{2 H3}	Z	CARBIDE
6	4	3.5	12	<input type="checkbox"/>
8	5	3.5	12	<input type="checkbox"/>
8	6	3.5	12	<input type="checkbox"/>
10	2	3.5	12	<input type="checkbox"/>
10	2	4.5	12	<input type="checkbox"/>
10	2	5.0	12	<input type="checkbox"/>
10	5	3.5	12	<input type="checkbox"/>
10	6	3.5	12	<input type="checkbox"/>
12	2	3.5	12	<input type="checkbox"/>
12	2	4.5	12	<input type="checkbox"/>
12	6	5.0	12	<input type="checkbox"/>
16	6	8.0	12	<input type="checkbox"/>
18	6	8.0	12	<input type="checkbox"/>
24	6	8.0	12	<input type="checkbox"/>

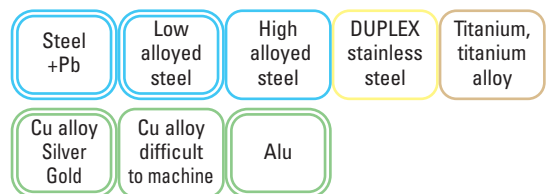

Module (m) = 0.03 - 1.00

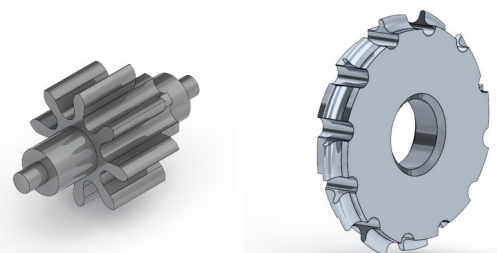

Coatings on request



SUPPORTING DISCS

DIXI 0700-A

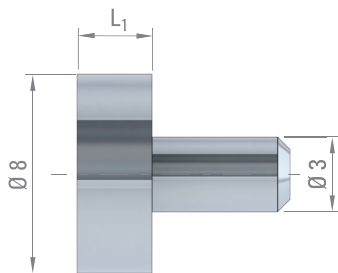

L₁ width from 3 to 5 mm
Until 8 slots

DIXI 0700-B

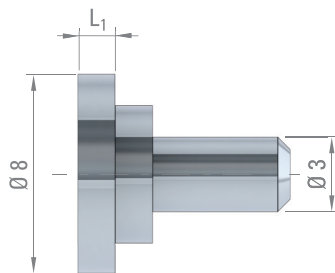

L₁ width from 1 to 2.99 mm
Until 8 slots

DIXI 0700-C

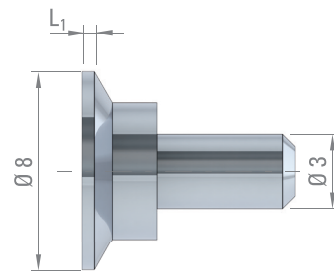

L₁ width from 0.05 to 0.99 mm
Until 8 slots

DIXI 0710-D

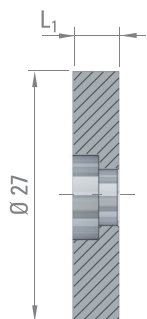

L₁ width 5 mm
Until 24 slots

DIXI 0710-E

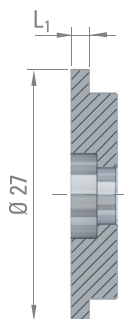

L₁ width from 1 to 4 mm
Until 24 slots

DIXI 0710-F

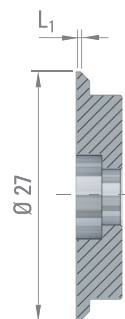

L₁ width from 0.05 to 0.99 mm
Until 24 slots

Special disc shapes for DIXI 0710

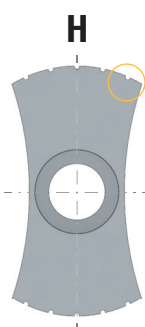
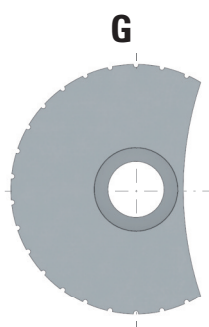

Slots shapes

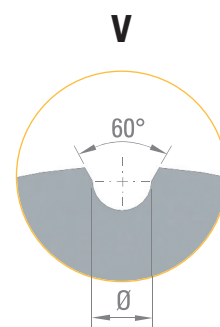
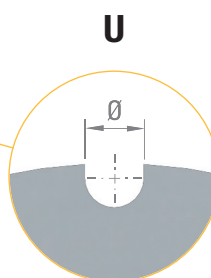

To complete for order, please.

	Number of discs	DIXI ref.	Width L ₁	Disc shape G or H	Slot shape U or V	Slot Ø	Number of slots
Ex.	1	0710-E	1	G	U	0.20	3
					V	0.24	5





Norm _____

Plan _____

DXF _____

Material to be machined _____

Module (m) _____

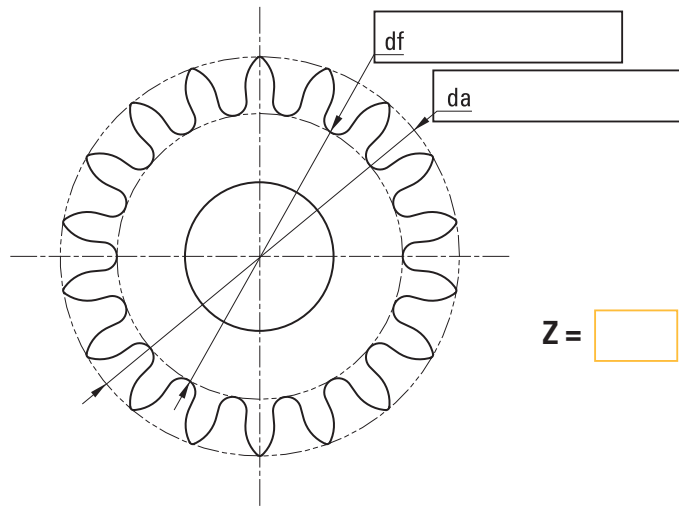

DIXI 1675

Helix angle (profile) R L

Number of profile _____

Coating _____

Quantity _____

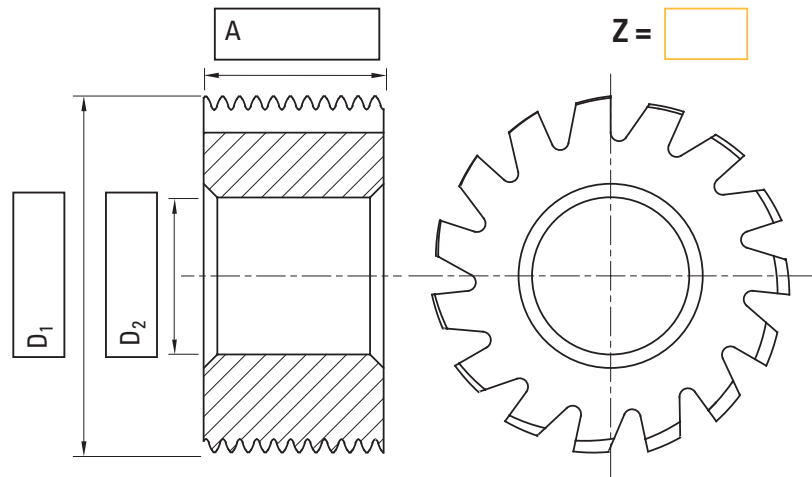

DIXI 1672

$Z = \square$

Helix angle (profile) R L

Number of profile _____

Coating _____

Quantity _____

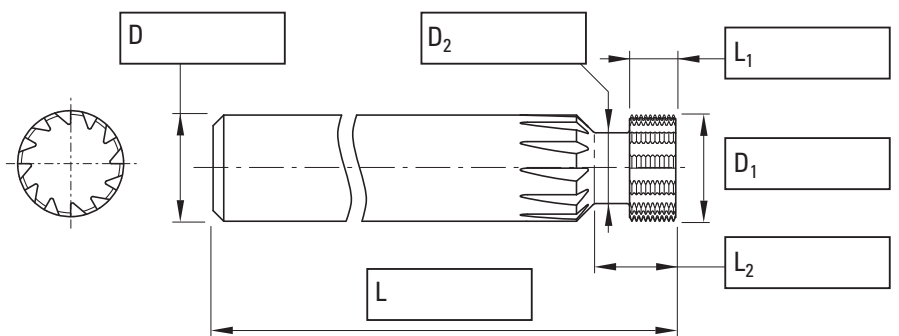

Notice _____





Norm

Plan

DXF

Material to be machined

Module (m)

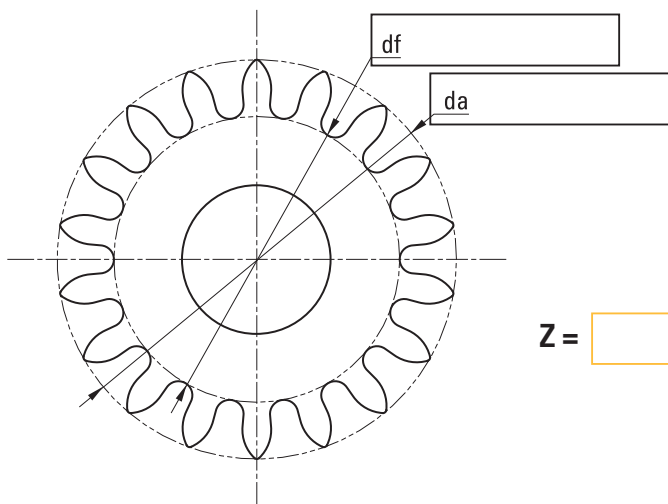

DIXI 1674

Coating

Quantity

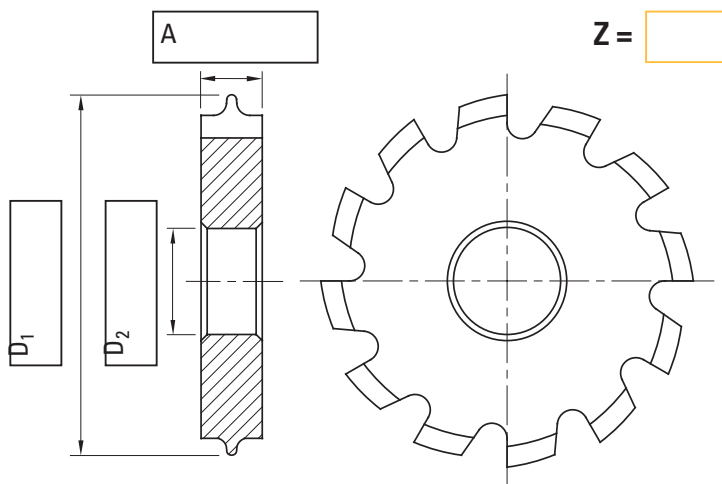

DIXI 1673

Coating

Quantity

$Z =$ []

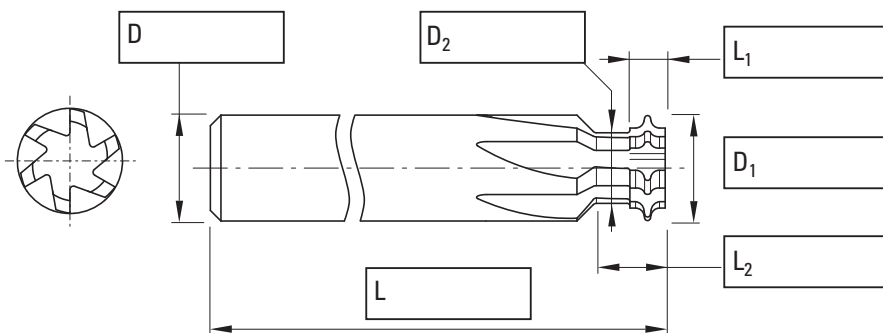

Notice





TOOLS ON REQUEST

Quantity

Material to be machined

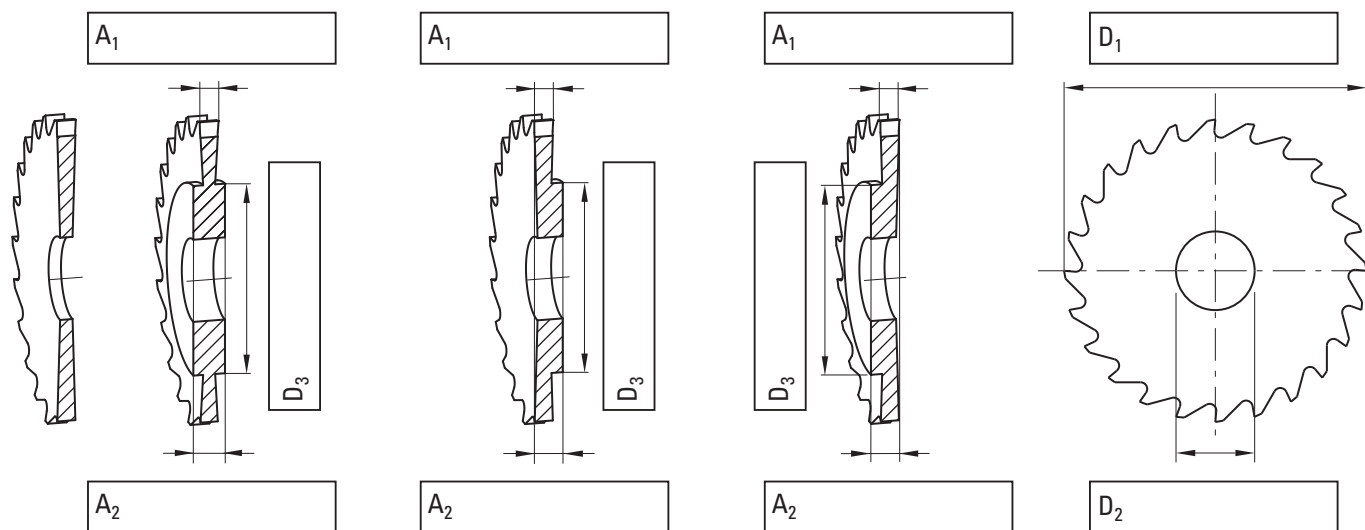

1640 L

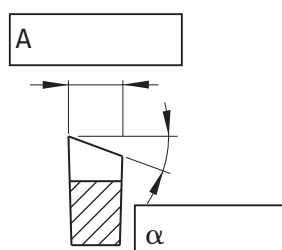

1640 R

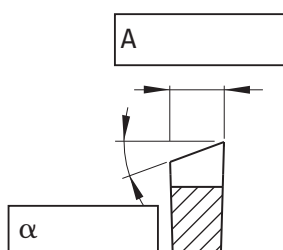

1643

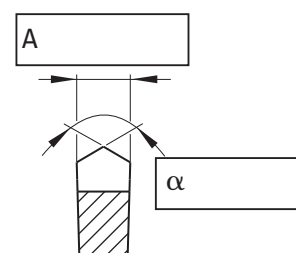

1650

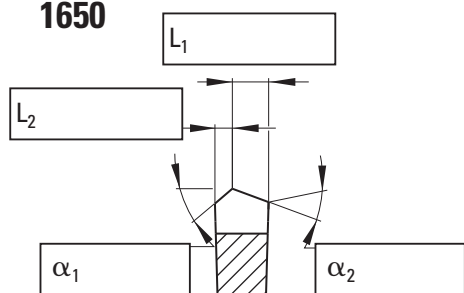

1650

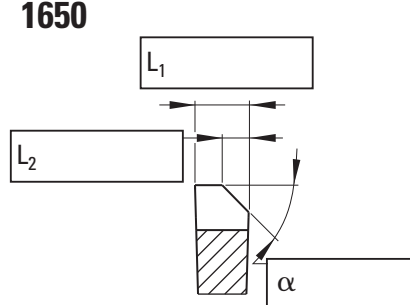

1650

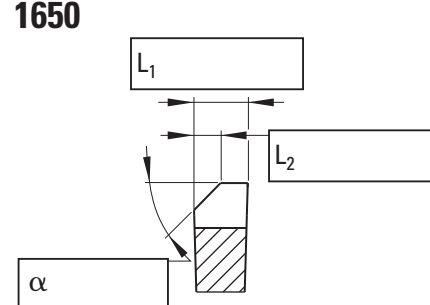

1650

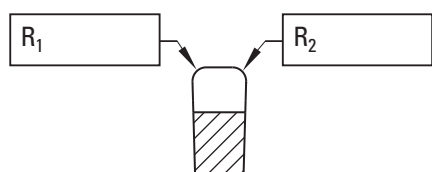

1654

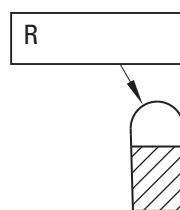

1650

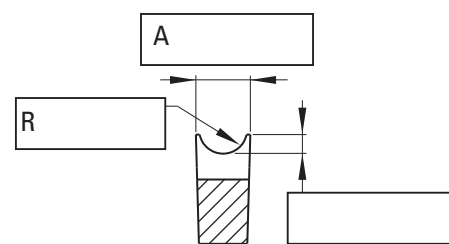



TOOLS ON REQUEST

T-SLOT CUTTERS

Z =

Quantity

Material to be machined

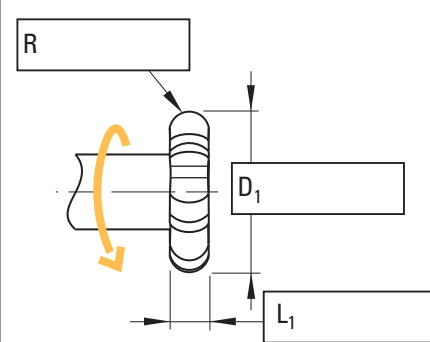
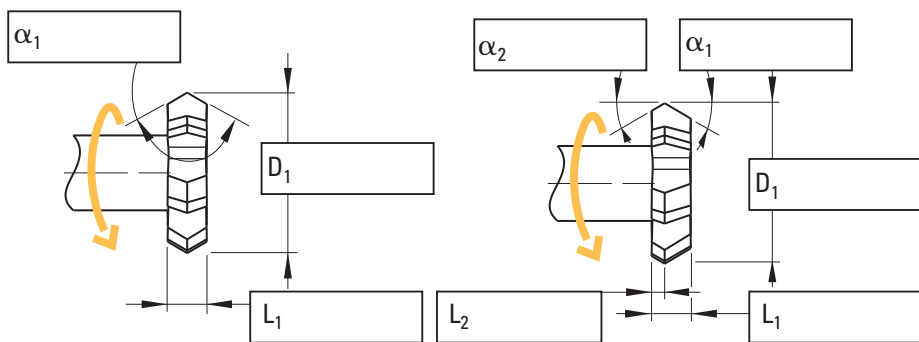
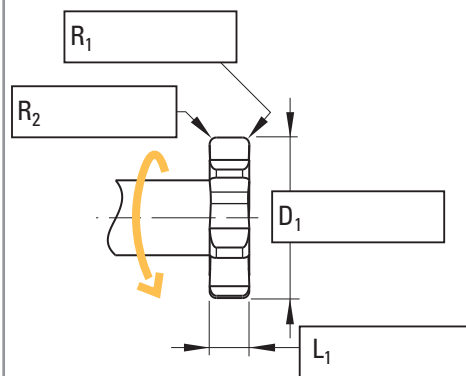
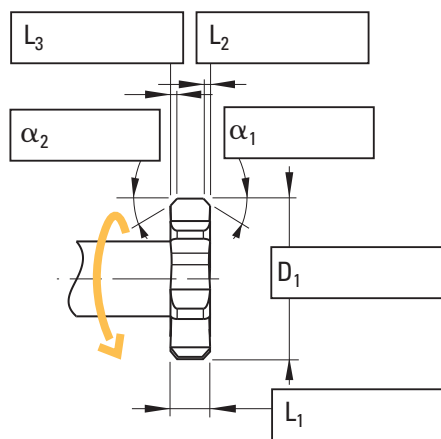
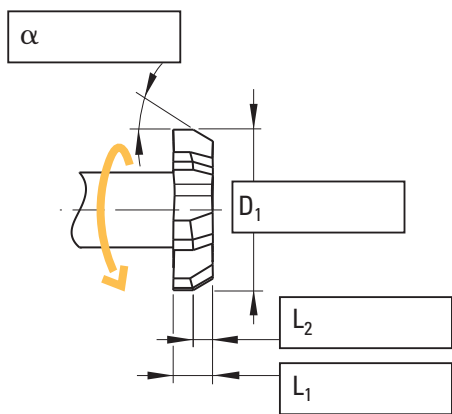
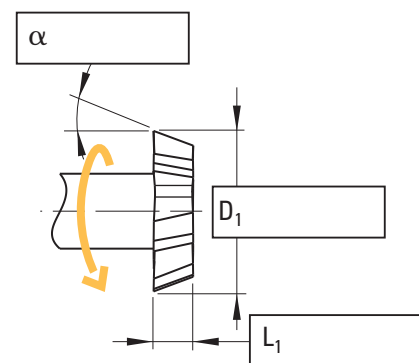
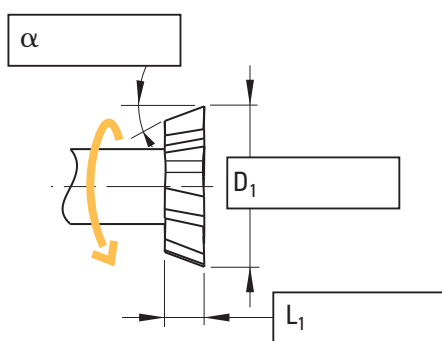
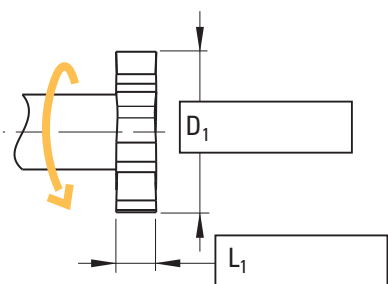
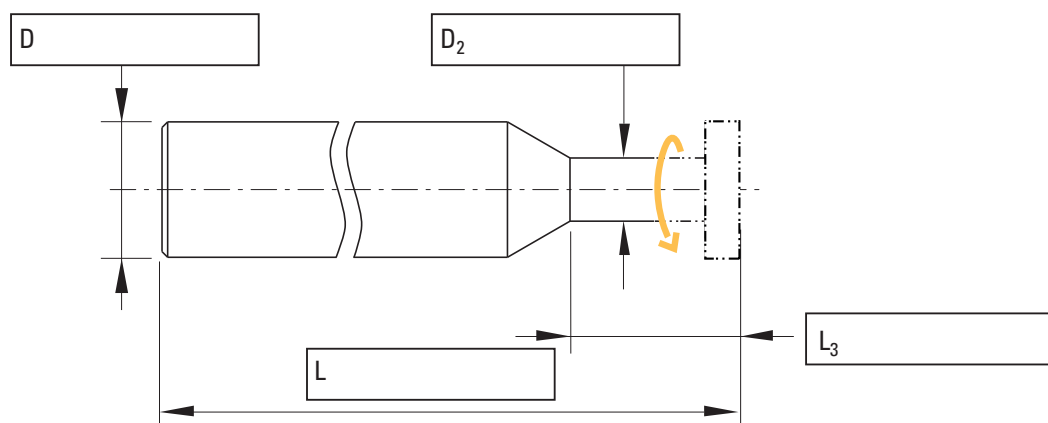

VISIT OUR E-QUOTATION ON WWW.DIXIPOLYTOOL.COM



CUTTING CONDITIONS

Material to be machined			CARBIDE	
			Vc [m/min]	
P	Unalloyed steel / Low alloyed steel	< 600 N/mm ²	80	140
P	Unalloyed steel / Low alloyed steel	600 – 1500 N/mm ²	50	80
P	Lead alloyed cutting steel		120	160
P	High alloyed steel	700 – 1500 N/mm ²	50	80
M	Stainless steel	400 – 700 N/mm ²	80	120
M	DUPLEX stainless steel	> 800 N/mm ²	50	80
K	Grey cast iron / Nodular pearlitic iron	< 250 HB	80	140
K	Alloyed cast iron / Nodular pearlitic iron	> 250 HB	50	80
K	Nodular ferritic cast iron / Malleable cast iron		50	80
S	Special alloys / Heat resistant stainless steel	Inconel Nimonic Hastelloy	20	30
S	Titanium, titanium alloys		30	70
N	Copper alloys - easy to machine (brass - bronze)		200	450
N	Copper alloys - difficult to machine / Aluminium bronze	(CuAlFe) (Ampco)	150	300
N	Aluminium alloys	Si < 8%	200	500
N	Cast aluminium	Si > 8%	200	450
N	Plastic		130	200
N	Gold, silver		140	180



$$n \text{ [tr/min]} = \frac{V_c \text{ [m/min]} \times 1000}{\pi \times D_1 \text{ [mm]}}$$

$$V_f \text{ [mm/min]} = n \text{ [tr/min]} \times f_z \text{ [mm]} \times z$$

Feed per tooth

f_z [mm]

$\emptyset D_1$ 15 - 30	$\emptyset D_1$ 30 - 50	$\emptyset D_1$ 50 - 80	$\emptyset D_1$ 80 - 125	$\emptyset D_1$ 125 - 160
0.002 - 0.004	0.003 - 0.007	0.004 - 0.008	0.004 - 0.012	0.004 - 0.012
0.001 - 0.004	0.002 - 0.005	0.002 - 0.008	0.003 - 0.012	0.003 - 0.012
0.003 - 0.007	0.004 - 0.008	0.005 - 0.010	0.005 - 0.010	0.005 - 0.012
0.001 - 0.004	0.002 - 0.005	0.002 - 0.008	0.003 - 0.012	0.003 - 0.012
0.001 - 0.004	0.002 - 0.005	0.002 - 0.008	0.003 - 0.012	0.003 - 0.012
0.001 - 0.004	0.002 - 0.005	0.002 - 0.008	0.003 - 0.012	0.003 - 0.012
0.002 - 0.004	0.003 - 0.007	0.004 - 0.01	0.004 - 0.01	0.004 - 0.01
0.001 - 0.004	0.002 - 0.005	0.002 - 0.008	0.003 - 0.012	0.003 - 0.012
0.002 - 0.004	0.003 - 0.007	0.004 - 0.01	0.004 - 0.01	0.004 - 0.01
0.001 - 0.004	0.002 - 0.005	0.002 - 0.008	0.003 - 0.012	0.003 - 0.012
0.001 - 0.004	0.002 - 0.005	0.002 - 0.008	0.003 - 0.012	0.003 - 0.012
0.003 - 0.007	0.004 - 0.008	0.005 - 0.010	0.005 - 0.010	0.005 - 0.012
0.001 - 0.004	0.002 - 0.005	0.002 - 0.008	0.003 - 0.012	0.003 - 0.012
0.003 - 0.007	0.004 - 0.008	0.005 - 0.010	0.005 - 0.010	0.005 - 0.012
0.003 - 0.007	0.004 - 0.008	0.005 - 0.010	0.005 - 0.010	0.005 - 0.012
0.003 - 0.010	0.004 - 0.010	0.005 - 0.012	0.005 - 0.012	0.005 - 0.015
0.003 - 0.007	0.004 - 0.008	0.005 - 0.010	0.005 - 0.010	0.005 - 0.012



CUTTING CONDITIONS

Material to be machined			CARBIDE	
			Vc [m/min]	
P	Unalloyed steel / Low alloyed steel	< 600 N/mm ²	80	140
P	Unalloyed steel / Low alloyed steel	600 – 1500 N/mm ²	50	80
P	Lead alloyed cutting steel		120	160
P	High alloyed steel	700 – 1500 N/mm ²	50	80
M	Stainless steel	400 – 700 N/mm ²	80	120
M	DUPLEX stainless steel	> 800 N/mm ²	50	80
K	Grey cast iron / Nodular pearlitic iron	< 250 HB	80	140
K	Alloyed cast iron / Nodular pearlitic iron	> 250 HB	50	80
K	Nodular ferritic cast iron / Malleable cast iron		50	80
S	Special alloys / Heat resistant stainless steel	Inconel Nimonic Hastelloy	20	30
S	Titanium, titanium alloys		30	70
N	Copper alloys - easy to machine (brass - bronze)		200	450
N	Copper alloys - difficult to machine / Aluminium bronze	(CuAlFe) (Ampco)	150	300

$$n \text{ [tr/min]} = \frac{V_c \text{ [m/min]} \times 1000}{\pi \times D_1 \text{ [mm]}}$$

$$V_f \text{ [mm/min]} = n \text{ [tr/min]} \times f_z \text{ [mm]} \times z$$

Feed per tooth **fz [mm]**

$\emptyset D_1$ 15 - 30	$\emptyset D_1$ 30 - 40	$\emptyset D_1$ 40 - 50	
0.0003 - 0.003	0.0003 - 0.003	0.0003 - 0.003	
0.0003 - 0.003	0.0003 - 0.003	0.0003 - 0.003	
0.0004 - 0.004	0.0004 - 0.004	0.0004 - 0.004	
0.0002 - 0.002	0.0002 - 0.002	0.0002 - 0.002	
0.0002 - 0.002	0.0002 - 0.002	0.0002 - 0.002	
0.0002 - 0.002	0.0002 - 0.002	0.0002 - 0.002	
0.0004 - 0.004	0.0004 - 0.004	0.0004 - 0.004	
0.0003 - 0.003	0.0003 - 0.003	0.0003 - 0.003	
0.0003 - 0.003	0.0003 - 0.003	0.0003 - 0.003	
0.0002 - 0.002	0.0002 - 0.002	0.0002 - 0.002	
0.0003 - 0.003	0.0003 - 0.003	0.0003 - 0.003	
0.0005 - 0.005	0.0005 - 0.005	0.0005 - 0.005	
0.0004 - 0.004	0.0004 - 0.004	0.0004 - 0.004	



CUTTING CONDITIONS

Material to be machined			CARBIDE	
			Vc [m/min]	
P	Unalloyed steel / Low alloyed steel	< 600 N/mm ²	150	200
P	Unalloyed steel / Low alloyed steel	600 – 1500 N/mm ²	120	170
P	Lead alloyed cutting steel		150	200
P	High alloyed steel	700 – 1500 N/mm ²	100	150
M	Stainless steel	400 – 700 N/mm ²	180	150
M	DUPLEX stainless steel	> 800 N/mm ²	100	150
K	Grey cast iron / Nodular pearlitic iron	< 250 HB	250	350
K	Alloyed cast iron / Nodular pearlitic iron	> 250 HB	180	250
K	Nodular ferritic cast iron / Malleable cast iron		150	250
S	Special alloys / Heat resistant stainless steel	Inconel Nimonic Hastelloy	50	100
S	Titanium, titanium alloys		80	150
N	Copper alloys - easy to machine (brass - bronze)		250	400
N	Copper alloys - difficult to machine / Aluminium bronze	(CuAlFe) (Ampco)	180	300
N	Aluminium alloys	Si < 8%	250	400
N	Cast aluminium	Si > 8%	200	350
N	Plastic		100	250
N	Gold, silver		180	300



$$n \text{ [tr/min]} = \frac{Vc \text{ [m/min]} \times 1000}{\pi \times D_1 \text{ [mm]}}$$

$$Vf \text{ [mm/min]} = n \text{ [tr/min]} \times fz \text{ [mm]} \times z$$

Feed per tooth **fz [mm]**

$\emptyset D_1$ 50	$\emptyset D_1$ 63	$\emptyset D_1$ 80	$\emptyset D_1$ 100	
0.002 - 0.008	0.002 - 0.008	0.002 - 0.008	0.002 - 0.008	
0.002 - 0.007	0.002 - 0.007	0.002 - 0.007	0.002 - 0.007	
0.002 - 0.009	0.002 - 0.009	0.002 - 0.009	0.002 - 0.009	
0.002 - 0.006	0.002 - 0.006	0.002 - 0.006	0.002 - 0.006	
0.002 - 0.006	0.002 - 0.006	0.002 - 0.006	0.002 - 0.006	
0.001 - 0.005	0.001 - 0.005	0.001 - 0.005	0.001 - 0.005	
0.003 - 0.009	0.003 - 0.009	0.003 - 0.009	0.003 - 0.009	
0.002 - 0.008	0.002 - 0.008	0.002 - 0.008	0.002 - 0.008	
0.002 - 0.008	0.002 - 0.008	0.002 - 0.008	0.002 - 0.008	
0.001 - 0.004	0.001 - 0.004	0.001 - 0.004	0.001 - 0.004	
0.002 - 0.008	0.002 - 0.008	0.002 - 0.008	0.002 - 0.008	
0.003 - 0.011	0.003 - 0.011	0.003 - 0.011	0.003 - 0.011	
0.003 - 0.010	0.003 - 0.010	0.003 - 0.010	0.003 - 0.010	
0.003 - 0.011	0.0033 - 0.011	0.003 - 0.011	0.003 - 0.011	
0.002 - 0.009	0.002 - 0.009	0.002 - 0.009	0.002 - 0.009	
0.003 - 0.010	0.004 - 0.010	0.005 - 0.012	0.005 - 0.012	
0.002 - 0.009	0.002 - 0.009	0.002 - 0.009	0.002 - 0.009	



CUTTING CONDITIONS

Materials to be machined			CARBIDE		CUTINOX	
			Vc [m/min]		Vc [m/min]	
P	Unalloyed steel / Low alloyed steel	< 600 N/mm ²	70	100		
P	Unalloyed steel / Low alloyed steel	600 – 1500 N/mm ²	70	90		
P	Lead alloyed cutting steel				70	100
P	High alloyed steel	700 – 1500 N/mm ²			40	70
M	Stainless steel	400 – 700 N/mm ²			60	90
M	DUPLEX stainless steel	> 800 N/mm ²			40	70
K	Grey cast iron / Nodular pearlitic iron	< 250 HB	70	100	90	110
K	Alloyed cast iron / Nodular pearlitic iron	> 250 HB	40	70	70	90
K	Nodular ferritic cast iron / Malleable cast iron		70	100	90	110
S	Special alloys / Heat resistant stainless steel	Inconel Nimonic Hastelloy			25	35
S	Titanium, titanium alloys		30	45		
N	Copper alloys - easy to machine (brass - bronze)		140	160		
N	Copper alloys - difficult to machine / Aluminium bronze	(CuAlFe) (Ampco)	120	140	170	190
N	Aluminium alloys	Si < 8%	180	260	230	340
N	Cast aluminium	Si > 8%	140	160	210	230
N	Plastic		240	260	300	340
N	Gold, silver		140	160	200	220



