



MOLETEADORES POR CORTE CUT-KNURLING TOOLS



MF 42



+ Características

- Recomendado para moleteados tipo RGE
- Ajuste de las moletas según diámetro a moletear mediante escala graduada
- Cabeza ajustable en altura para el alineamiento de las moletas
- Cabeza reversible para trabajar a derechas o izquierdas
- Ejes de metal duro

+ Features

- Recommended for RGE type knurling
- Easy setting to the workpiece diameter by means of a graduated scale
- Up&down tool head alignment for knurls centering
- Tool with reversible head able to fit on left-hand or right-hand lathes
- Carbide pins

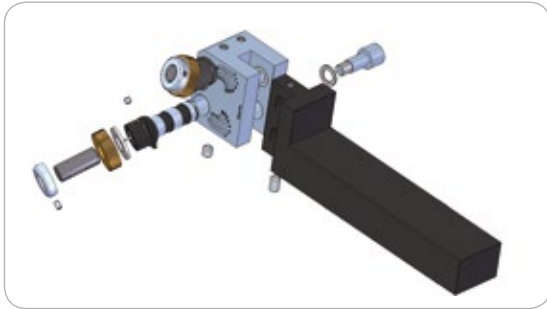
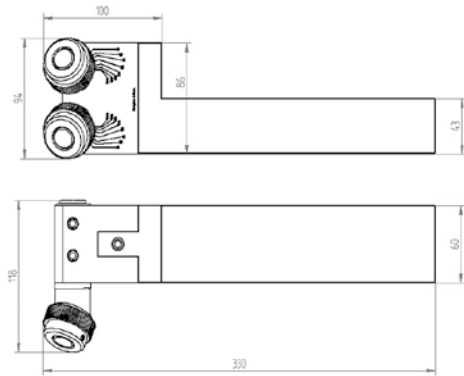

+ Avance Feed



+ Formas de moleteados realizables Feasible knurling forms

	R RGE 30°	R RGE 45°
Tipo de moleteado Knurling form		
Con moleta tipo With knurl type	AA + AA	BL15° + BR15°
Avances permitidos Allowed feeds	F	F

R Moleteados recomendados | Recommended knurlings

Herramienta Tool					
Código Code	Referencia Reference	Versión Version	Capacidad Capacity	Moleta Knurl	Kg Kg
01240100	MF 42.12.40	R+L	∅ 30 ÷ 3000	42x12x18	9.0

Repuesto Spare Part	
Código Code	Referencia Reference
01985300	EAT 42.12

