



# MOLETEADORES POR DEFORMACIÓN FORM-KNURLING TOOLS



## M7

### + Características

- Recomendado para moleteados tipo RGE
- Cabeza basculante para el autocentrado de las moletas
- Para trabajos no repetitivos
- Ejes de HSS fijados mediante circlip

### Tipos de máquinas

- Para tornos convencionales y CNC

### + Features

- Recommended for RGE type knurling
- Pivoting head for knurls self-centering
- For non-repetitive works
- HSS pins fixed by circlip

### Machine Types

- For conventional and CN lathes



### + Avance Feed

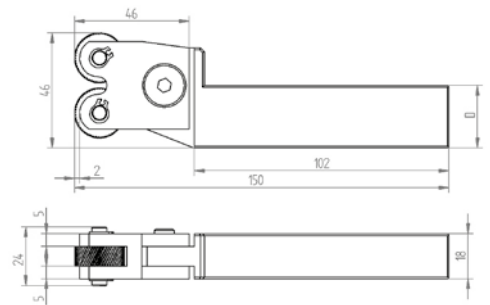
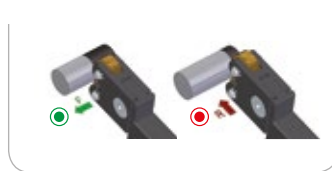

### + Formas de moleteados realizables Feasible knurling forms

	RAA	RGE 30°	RGE 45°
Tipo de moleteado Knurling form			
Con moleta tipo With knurl type	AA+AA	BL30° + BR30°	BL45° + BR45°
Avances permitidos Allowed feeds	F ● R ●	F ● R ●	F ● R ●

**R** Moleteados recomendados | Recommended knurlings

Herramienta   Tool						
Código Code	Referencia Reference	Versión Version	Capacidad Capacity	Moleta Knurl	D	Kg Kg
01160200	M7N 20.08.20	R+L	Ø 8-200	20x8x6	20	0.7
01160300	M7N 20.08.25	R+L	Ø 8-200	20x8x6	25	0.7

Repuesto   Spare Part		
Código Code	Referencia Reference	
01992701	EM3/M7-SET	