

**第5弾！
フェニックス
ロングネック
ボール登場！**

Phoenix Long Neck Ball Nose
End Mills are Launched

生産性向上を目指す金型メーカー様に
 保有設備の能力をフルに使って、
 更なるコストダウンと短納期を実現して頂きたい！
 これが、PHXシリーズの想いです！

The Phoenix Series has been developed with the following objective in mind:
 To help mold manufacturers realize further cost reductions and
 shorter delivery times utilizing their existing equipment.

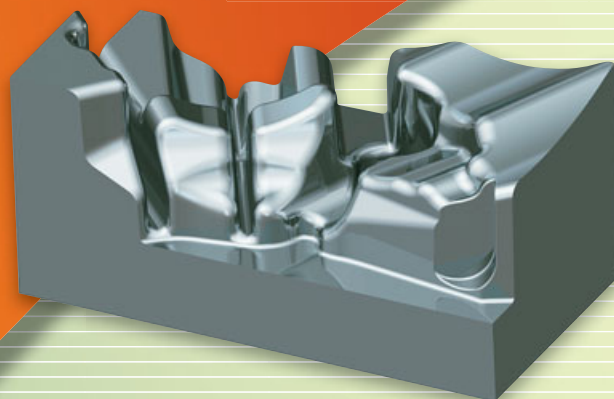

OSG Phoenix Series

WORK SIZE 200×100×100mm
DH31S

【ツールレイアウト】 被削材質：DH31S 47HRC 使用機械：国産高精度輪郭制御付きマシニングセンタ 主軸タイプ：BT50 最高回転数：6,000min⁻¹
 Tool layout Work Material Machine: Japanese high precision machining center with contour control Main spindle Maximum RPM

工程番号 Process	加工内容 Milling process	使用工具 Tool	突き出し量 Projection Length	残り代 Remnants (mm)	回転速度 (min ⁻¹) Speed	送り速度 (mm/min) Feed	軸方向 切込深さ (mm) a_p	径方向 切込深さ (mm) a_e, p_f	ホルダ Holder	切削距離 (m) Milling Length	切削時間 Cutting Time
1	無垢材削り出し等高線荒取り加工 (トロコイド加工) Initial contour roughing of solid material (trochoidal milling)	PHC09R032SS32-3S SDMT09T308SR-GM XP2040	66	0.3	895	2,000	1	16	ミーリングチャック Milling Chuck	15.28	0:09:51
2	↓	PHC09R032SS32-3S SDMT09T308SR-GM XP2040	66	0.3	895	2,000	1	16	ミーリングチャック Milling Chuck	15.67	0:10:11
3	↓	PHC09R032SS32-3S SDMT09T308SR-GM XP2040	66	0.3	895	2,000	1	16	ミーリングチャック Milling Chuck	15.11	0:10:02
4	↓	PHC09R032SS32-3S SDMT09T308SR-GM XP2040	66	0.3	895	2,000	1	16	ミーリングチャック Milling Chuck	11.27	0:08:36
5	全体絞り込み等高線荒加工 (トロコイド加工) Detail refining of contour roughing (trochoidal milling)	PHX-DFR φ12×R2	57	0.05	1,440	1,080	0.4	1.7	焼きばめホルダ Shrink fit holder	184.98	3:43:22
6	削り残り部等高線荒取り加工 (負荷送り速度制御) Contour roughing of remaining areas (load feed control)	PHX-PC-DBT R3×1°×62.3	62.3	0.05	2,035	960	0.25	1.2	焼きばめホルダ Shrink fit holder	54.83	1:35:52
7	平坦部走査線加工 (負荷送り速度制御) Linear milling of flat surfaces (load feed control)	↓	62.3	0.03	2,035	960	0	0.35	焼きばめホルダ Shrink fit holder	39.72	0:48:12
8	削り残り部等高線荒取り加工 (負荷送り速度制御) Contour roughing of remaining areas (load feed control)	PHX-PC-DBT R2×1°×40	44	0.05	2,300	870	0.15	0.8	焼きばめホルダ Shrink fit holder	43.81	1:22:16
9	削り残り部等高線荒取り加工 (負荷送り速度制御) Contour roughing of remaining areas (load feed control)	PHX-PC-DBT R1×1°×40	48	0.05	3,500	560	0.06	0.4	焼きばめホルダ Shrink fit holder	6.07	0:16:47
10	等高線仕上げ加工 Contour finishing	PHX-PC-DBT R4×1°×63.3	63.3	0	4,300	1,100	0.24	-	焼きばめホルダ Shrink fit holder	101.87	2:04:25
11	平坦部走査線仕上げ加工(エリア1) Linear finishing of flat surfaces (area 1)	↓	63.3	0	4,300	1,100	-	0.24	焼きばめホルダ Shrink fit holder	2.37	0:03:15
12	平坦部走査線仕上げ加工(エリア2) Linear finishing of flat surfaces (area 2)	↓	63.3	0	4,300	1,100	-	0.24	焼きばめホルダ Shrink fit holder	57.66	1:02:24
13	隅部取り残り仕上げ加工 (負荷送り速度制御) Finishing of remaining corner areas (load feed control)	↓	63.3	0	4,300	1,100	0.24	0.28	焼きばめホルダ Shrink fit holder	28.69	0:55:13
14	平面隅部等高線仕上げ加工 Contour finishing of planar corner areas	PHX-PC-DFR φ8×R2×1°×63.3	63.3	0	1,800	400	0.12	2	焼きばめホルダ Shrink fit holder	4.45	0:12:18
15	平面部仕上げ加工 Finishing of planar areas	↓	63.3	0	1,800	400	-	2	焼きばめホルダ Shrink fit holder	2.23	0:05:54
16	取り残り部等高線仕上げ加工 Contour finishing of remaining areas	PHX-PC-DBT R3×1°×62.3	62.3	0	4,700	750	0.18	0.18	焼きばめホルダ Shrink fit holder	31.37	0:47:26
17	取り残り部等高線仕上げ加工 Contour finishing of remaining areas	PHX-PC-DBT R2×1°×40	44	0	3,200	560	0.12	0.12	焼きばめホルダ Shrink fit holder	35.43	1:11:35
18	隅部取り残り仕上げ加工 (負荷送り速度制御) Finishing of remaining corner areas (load feed control)	↓	44	0	3,200	560	0.12	0.18	焼きばめホルダ Shrink fit holder	36.23	1:14:08
19	等高線部分仕上げ加工 Partial contour finishing	↓	44	0	3,200	560	0.12	0.12	焼きばめホルダ Shrink fit holder	14.37	0:34:52
20	隅部取り残り仕上げ加工 (負荷送り速度制御) Finishing of remaining corner areas (load feed control)	PHX-PC-DBT R1×1°×40	48	0	3,500	250	0.06	0.09	焼きばめホルダ Shrink fit holder	12.71	0:51:41

トータル加工時間 17:28:20
Total operation time

Phoenix ディープフィーダー ブルノーズシリーズ!

斬

Deep Feeder Bull Nose Series!

従来品ハイフィーダーブルノーズ(PHX-CRT)の**3次元ネガ形状**に、ディープフィーダーボールシリーズの

Thermolysis効果をプラス! 究極のブルノーズで、びびり易い深い部位の加工や難削材加工に、より高効率を実現します!

In addition to the negative shape of the conventional PHX-CRT high feeder bull nose, it achieves the thermolysis effect of the deep feeder ball series. The superior bull nose performs exceptionally when making deep cuts that are ordinarily susceptible to chattering or when working in materials that are difficult to machine.

ハイフィーダーブルノーズ(PHX-CRT)のR精度は±0.01mm、ディープフィーダーブルノーズシリーズは±0.03mm。

ディープフィーダーブルノーズシリーズとハイフィーダーブルノーズ(PHX-CRT)は、要求R精度に応じて、使い分けて下さい。

The precision of the PHX-CRT high feeder bull nose is ± 0.01 mm, and the deep feeder bull nose series is ± 0.03 mm.

Use the deep feeder bull nose series or the PHX-CRT high feeder bull nose to suit your radius precision requirements.

Thermolysis効果とは The Thermolysis Effects are...

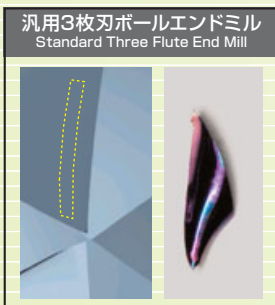
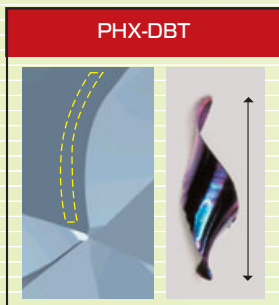

強スパイラルギャッシュにより切れ刃が長くなり、その分厚さが薄くなることで、切削熱も伝わりやすく、工具刃先や被削材に熱が残りにくい。

Due to the strong spiral gash, the cutting edge becomes longer and the chip thickness is reduced, so it becomes easier to dissipate cutting heat and the cutting edge and workpiece are less effected by heat buildup.

3次元ネガ形状とは A Three-Dimensional Negative Form is...

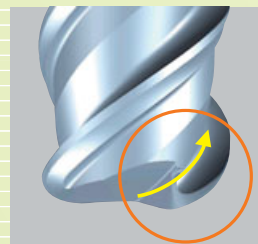

- ① 中心部は切れ味を持たせるためにすくい角を強くし、外周部にかけて剛性を持たせるため、すくい角を弱くしている。
- ② 切りくずの流動性を向上させ、切削熱を低減し長寿命化を図る。

1. A form where the weaker central portion of the cutting edge has a slight negative angle, and the easily broken outer portion has a strong negative angle
2. Designed for long tool life by increasing chip evacuation and reducing heat buildup

ねじれ角による効果(同切込みでの比較) Effect based on helix angle (comparison of cut length)

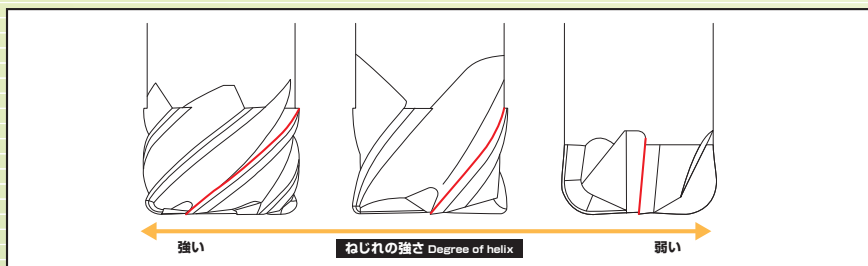

例 一刃切込みが0.2mm(t=0.2)の場合の刃先のねじれによる切りくずのイメージ ※R形状無視

Ex. Images of cutting chips produced based on helix angle where the cut length is 0.2 mm (t = 0.2 mm) ※ Radius ignored

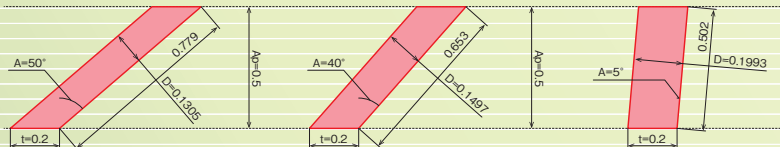

あくまでも二次元的な表現です。実際の加工とは異なります。

The above is strictly a conceptual analysis. Result may vary based on milling condition.

切削条件が同じ場合、切りくずの体積は変わらないが、切りくずの形状が変わることで発熱量も抵抗も変わる。

Under identical cutting conditions, even though the sizes of the cutting chips are the same, the amount of resistance and heat released will differ based on the change in chip shape.

ディープフィーダーブルノーズシリーズで、直彫加工領域を拡大頂き、びびりを回避した高精度な荒加工で、更なる生産性向上に挑戦下さい。

Use the deep feeder bull nose series to expand the scope of your mold milling work, and further improve your productivity through high-precision roughing without chattering.

ディープフィーダーブルノーズシリーズは、3種類をご用意。幅広い加工に対応します!

Three types of deep feeder bull nose series are available for a wide range of milling work.

- 標準形状 PHX-DFR
Standard shape
- ロングネック形状 PHX-LN-DFR
Long neck shape
- ペンシルネック形状 PHX-PC-DFR
Pencil neck shape



深堀加工事例 深さ120mm L/D=15D

Phoenixシリーズで高能率、深堀加工！

High efficiency deep groove milling is made possible with the Phoenix Series!

WORK SIZE 50×50×150mm
DAC55 53HRC

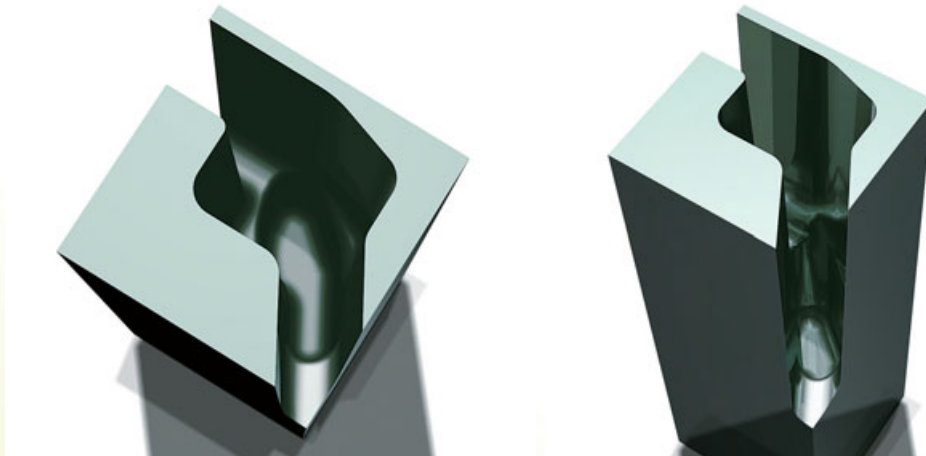

被削材質：DAC55 53HRC 使用機械：国産高精度輪郭制御付きマシニングセンタ 主軸タイプ：BT40 最高回転数：12,000min⁻¹
Work Material Machine: Japanese high precision machining center with contour control Main spindle Maximum RPM

工程番号 Process	加工内容 Milling process	使用工具 Tool	突き出し量 Projection Length	残り代 (mm) Remnants	回転速度 (min ⁻¹) Speed	送り速度 (mm/min) Feed	軸方向 切込深さ (mm) Ap	径方向 切込深さ (mm) Ae, pf	ホルダ Holder	切削距離 (m) Milling Length	切削時間 Cutting Time
1	等高線荒取り加工(トロコイド加工) (0~50mm) Contour roughing (trochoidal milling)	PHX-PC-DFR φ8×R2×1°×50	53	0.03	2,300	1,380	0.35	1.6 (0.1)	ミーリングチャック Milling Chuck	186.4	2:26:13
2	等高線荒取り加工(トロコイド加工) (50~80mm) Contour roughing (trochoidal milling)	PHX-PC-DFR φ8×R2×1°×63.3	81	0.03	1,500	900	0.25	1.6 (0.1)	ミーリングチャック Milling Chuck	150.3	3:08:23
3	等高線仕上げ加工 (0~79.9mm) Contour finishing	↓	81	0	1,800	1,080	0.4	-	ミーリングチャック Milling Chuck	39.8	0:33:13
4	等高線荒取り加工(トロコイド加工) (80~90mm) Contour roughing (trochoidal milling)	PHX-PC-DFR φ8×R2×1°×63.3	91	0.03	1,600	600	0.15	1.6 (0.1)	ミーリングチャック Milling Chuck	80.6	2:25:03
5	等高線荒取り加工(トロコイド加工) (90~100mm) Contour roughing (trochoidal milling)	PHX-PC-DFR φ8×R2×1°×63.3	101	0.03	1,200	480	0.15	1.6 (0.1)	ミーリングチャック Milling Chuck	75.9	2:50:59
6	等高線仕上げ加工 (80~99.9mm) Contour finishing	↓	101	0	1,500	900	0.3	-	ミーリングチャック Milling Chuck	15.1	0:13:18
7	等高線荒取り加工(トロコイド加工) (100~115mm) Contour roughing (trochoidal milling)	PHX-PC-DFR φ8×R2×1°×120.6	121	0.03	1,200	480	0.1	1.6 (0.1)	ミーリングチャック Milling Chuck	97.5	2:15:39
8	等高線荒取り加工(トロコイド加工) (115~130mm) Contour roughing (trochoidal milling)	PHX-PC-DFR φ8×R2×1°×120.6	131	0.03	1,200	480	0.1	1.6 (0.1)	ミーリングチャック Milling Chuck	67.4	2:08:36
9	等高線仕上げ加工 (100~130mm) Contour finishing	↓	131	0	1,320	600	0.3	-	ミーリングチャック Milling Chuck	6.9	0:13:48
10	平坦部走査線中仕上げ加工 Semi-finishing of linear flat surface	PHX-PC-DBT R4×1°×120.6	131	0.02	1,320	200	0.05	1.15	ミーリングチャック Milling Chuck	1.6	0:08:48
11	等高線仕上げ加工 (0~130mm) Contour finishing	↓	131	-0.03	1,320	450	0.2	-	ミーリングチャック Milling Chuck	163.9	4:07:37
12	平坦部走査線仕上げ加工 Finishing of linear flat surfaces	↓	131	-0.01	1,320	200	-	0.1	ミーリングチャック Milling Chuck	1.2	0:06:11

全工程 ミストクーラント Mist coolant used in all processes

- ・たわみを考慮している為、径方向に対して、マイナス設定にしてあります。
- ・()内の値は、形状輪郭部直前のオフセットのピッチです。(削り残り補正)
- ・Figures have been set in the negative range with the consideration of possible tool deflection.
- ・The values in parentheses are the step-over offsets before milling the nonlinear contour areas (milling of remaining materials).

トータル加工時間 20:37:48
Total operation time

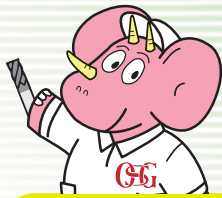

Phoenixシリーズをより良く使うために

■ 回転そのまま、送り倍増で高能率！

Doubling the feed rate while using the same RPM!

Rev Limit Overdrive 加工 (レプリミット オーバードライブ)

チップルームが大きい外径6mm以上の工具では、被削材によって通常の送り速度の120%～300%で加工が可能です。形状輪郭切削部以外で送り速度を使い分けることで高精度と能率を両立できます。

※CAMによって適用できない事があります。

For tools over 6 mm in diameter with large chip pockets, feed rates can be increased 120% to 300% depending on the material. By varying the feed rate based on cutting areas and utilizing a higher feed rate during rough milling, a balance of quality and efficiency can be achieved. ※ Result may vary based on CAM capability.

● 経路のイメージ An image of the milling paths

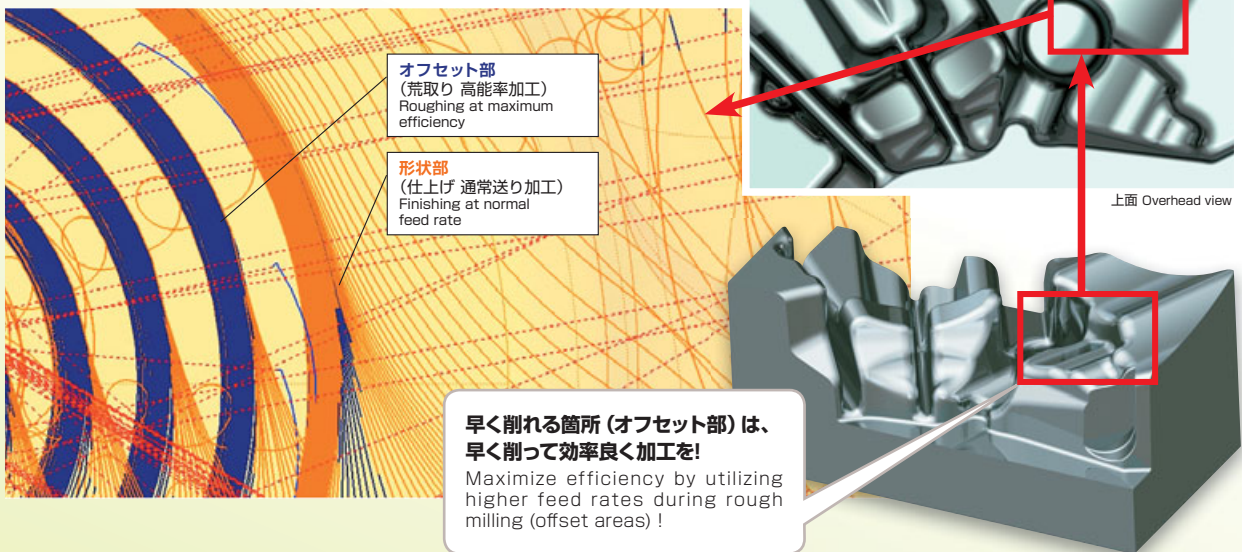

ユーザ事例 Milling Examples

A社様 鋳造金型 荒取り兼中仕上げ加工 Company A Casting die Roughing and semi-finishing		約 180%UP about 180%UP
使用工具 Tool	PHX-PC-DBT R3×2°×33.6	
被削材質 Work Material	SKD61 (38HRC)	
切削速度 Milling Speed	150m/min (8,000min ⁻¹)	
送り速度 Feed	形状輪郭部 Nonlinear Contour Areas	2,400mm/min (0.1mm/t)
	オフセット切削部 Offset Cutting Areas	4,300mm/min (0.18mm/t)
切込深さ Depth of Cut	a _p =0.4mm	
	Pf=0.3mm (輪郭前) Pf=1.2mm (オフセット) Before contour milling Offset cutting areas	
突き出し量 Projection Length	35mm (L/D=5.8)	
切削油剤 Coolant	エアブロー Air Blow	
使用機械 Machine	立形マシニングホルダ(焼きばめホルダ) (BT50) Vertical Machining Center (Shrink fit holder)	

B社様 樹脂金型 荒取り兼仕上げ加工 Company B Injection mold Roughing and finishing		約 340%UP about 340%UP
使用工具 Tool	PHX-LN-DFR φ10×R2×70	
被削材質 Work Material	S50C (94HRB)	
切削速度 Milling Speed	78m/min (2,500min ⁻¹)	
送り速度 Feed	形状輪郭部 Nonlinear Contour Areas	1,500mm/min (0.2mm/t)
	オフセット切削部 Offset Cutting Areas	5,200mm/min (0.7mm/t)
切込深さ Depth of Cut	a _p =0.2mm a _e =3mm	
突き出し量 Projection Length	70mm (L/D=7)	
切削油剤 Coolant	水溶性切削油剤 Water Soluble	
使用機械 Machine	立形マシニングホルダ(汎用ホルダ) (BT40) Vertical Machining Center (General-purpose holder)	



Phoenixシリーズをより良く使うために

PHX-PC (ペンシルネック) シリーズの突き出し長さ換算表

Overhang conversion table of the PHX-PC (Pencil Neck) Series

ペンシルネック形状による剛性アップを、突き出し長さとして換算する為の表です。
下記表を用いて突き出し長さを算出し、切削条件の参考にして下さい。

The following table may be used to calculate the new overhang length, since rigidity has been improved with the use of Pencil Neck.
Please use the following table to calculate the overhang length and use it as a reference for your cutting condition.

[公式] **手順1** 突き出し長さ ÷ 工具刃径 = L/D **手順2** 突き出し長さ × 割合 = ストレートシャंक換算の突き出し長さ
Step1 Overhang Mill Diameter Step2 Overhang percentage Overhang of the straight shank conversion

例) PHX-PC-DBT R3 × 2° × 62.3 で、突き出し長さを 65mm で加工をした場合 (赤丸部分) Ex.) PHX-PC-DBT R3 × 2° × 62.3, milling with an overhang of 65mm

手順1 (突き出し長さ: 65mm) ÷ (工具刃径: φ6) = 10.83D → 約 11D 下記表から「11D の 2°」の割合 (63.8%) を確認
Step1 Overhang Mill Diameter About Approximately Confirm the percentage from the below table "11D and 2°" (63.8%)
手順2 (突き出し長さ: 65mm) × (割合: 63.8%) = 41.47mm → ストレートシャंक換算で突き出し長さ 45mm の切削条件を参考に設定
Step2 Overhang percentage Based on this straight shank conversion, the overhang is calculated to be 45 mm. Please refer to it as the new cutting condition.

▶ ペンシルネックを使うことによって、突き出し長さ 65mm でも、ストレートシャंकの 45mm 相当の切削条件で削ることが出来、**剛性が確保** 出来ます。
By utilizing the Pencil Neck, even if the overhang is 65 mm, the cutting condition can be set equivalent to a 45 mm straight shank tool while keeping the same rigidity.

注) 上記は工具単体での剛性を計算した割合です。実際に使用するホルダ、機械等の剛性によって調整して下さい。

Note: The above percentages are calculated based on the rigidity of the individual tool. Please make necessary adjustments based on the conditions of your tool holder and machining center.

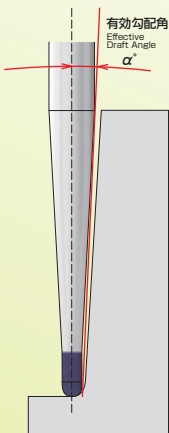

有効勾配角 Effective Draft Angle α°	首部テーパ半角 θn	突き出し長さ L/D															
		3D	4D	5D	6D	7D	8D	9D	10D	11D	12D	13D	14D	15D	16D	20D	
0.5°		99.7%	98.3%	96.6%	95.2%	93.6%	92.1%	90.7%	89.3%	88.0%	86.7%	85.4%	84.1%	82.9%	81.8%	77.4%	
1°		98.3%	95.5%	92.6%	89.8%	87.1%	84.6%	82.2%	80.0%	77.9%	75.9%	74.0%	72.2%	70.5%	68.8%	62.9%	
1.5°		97.0%	93.0%	88.8%	85.2%	81.6%	78.4%	75.4%	72.7%	70.1%	67.7%	65.5%	63.4%	61.4%	59.6%	53.2%	
2°		95.7%	90.5%	85.6%	81.0%	76.9%	73.1%	69.8%	66.7%	63.8%	61.3%	58.8%	56.6%	54.6%	52.7%	46.2%	

この表は、2°以下の剛性の弱いサイズに活用下さい。2°を超えるサイズに関しては、加工に応じて条件を設定して下さい。
Please use this chart for sizes under 2° with low rigidity. For sizes over 2°, please adjust accordingly based on milling condition.

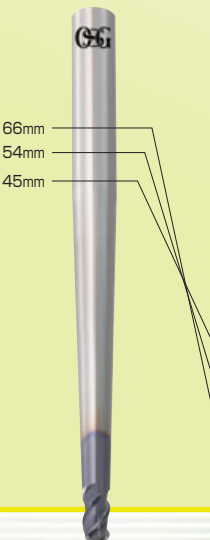

突き出し長さが長くなっても、一刃あたりの送り量は落としません。
シングルネックタイプなら、**同一工具で突き出し長さを変えて加工**ができます。

Even with a long projection length, feed per cutting edge will not decrease.
Use the single-neck type for continuous machining with the same tool by simply changing the length of projection.

PHX-PC-DBT (R3 × 1.5° × 43.2) を用いた中仕上げ工程

Semi-finishing process using PHX-PC-DBT (R3 × 1.5° × 43.2)

突き出し量 Projection Length		回転速度 Speed (min ⁻¹)	切削速度 Milling Speed (m/min)	送り速度 Feed (mm/min)	一刃あたりの 送り量 Feed per tooth (mm/t)	切込深さ Depth of Cut (mm)	
mm	L/D					a _p	P _f
45	7.5	4,300	80	3,600	0.28	0.5	1.3
54	9	2,670	50	3,240	0.4	0.34	1
66	11	1,660	30	2,590	0.52	0.23	1



Phoenixシリーズの能力をより発揮させるために

To maximize performance of the Phoenix Series

■ 切削条件の計算式

How to calculate cutting conditions

**切削条件を考える時に
下の式を使うと便利だよ!**

When you calculate the cutting conditions, it is much more convenient if you use the following equations!



[計算式]

n = 回転速度 (min⁻¹)

$$n = Vc \div 3.14 \div Dc \times 1,000$$

*Dcは外径
Dc=diameter

Vc = 切削速度 (m/min)

$$Vc = n \times 3.14 \times Dc \div 1,000$$

*Dcは外径
Dc=diameter

Vf = 送り速度 (mm/min)

$$Vf = n \times z \times fz$$

*zは刃数
Z=number of flutes

fz = 1刃辺りの送り量 (mm/t)

$$fz = Vf \div z \div n$$

*zは刃数
Z=number of flutes

例 PHX-DFR $\phi 10 \times R2$ を電卓で計算する場合
Ex. Calculating the PHX-DFR $\phi 10 \times R2$ with a calculator



使用工具 Tool	PHX-DFR $\phi 10 \times R2$
切削速度 Milling Speed	39.25m/min (1,250min ⁻¹)
送り速度 Feed	1,500mm/min (0.4mm/t)

$$39.25\text{m/min} \div 3.14 \div \phi 10 \times 1,000$$

$$n = 1,250\text{min}^{-1}$$

$$1,250\text{min}^{-1} \times 3.14 \times \phi 10 \div 1,000$$

$$Vc = 39.25\text{m/min}$$

$$1,250\text{min}^{-1} \times 3\text{刃} \times 0.4\text{mm/t}$$

$$Vf = 1,500\text{mm/min}$$

$$1,500\text{mm/min} \div 3\text{刃} \div 1,250\text{min}^{-1}$$

$$fz = 0.4\text{mm/t}$$

また、カスプハイト、ピックフィードにも配慮下さい。カスプハイト、ピックフィードは下記参照下さい。
Also take the cusp height and pick feed into account. The cusp height and pick feed are indicated below.

■ カスプハイトの求め方 (μm)

The value of cusp height (μm)

[計算式]

h = カスプハイト (μm)

$$h = R - \sqrt{R^2 - \left(\frac{Pf}{2}\right)^2}$$

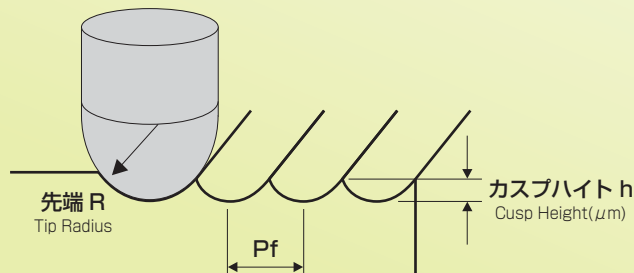

例 PHX-DBT R5 × 100 Pfが 0.3mm を
電卓で計算する場合
Ex. Calculating the PHX-DBT R5 × 100 with a calculator

$$h = R - \sqrt{R^2 - \left(\frac{Pf}{2}\right)^2}$$

↓

$$5 \times 5 = 25$$

↓

$$0.3 \div 2 = 0.15$$

↓

$$0.15 \times 0.15 = 0.0225$$

↓

$$25 - 0.0225 = 24.9775$$

↓

$$\sqrt{24.9775}$$

↓

$$\sqrt{\quad} = 4.99775$$

↓

$$5 - 4.99775$$

↓

$$h = 0.00225\mu\text{m}$$

■ 中仕上げ、仕上げ加工の切込み量の目安 (mm)

Approximate depth of cut for semi-finishing and finishing

・中仕上げの切込み量目安
Approximate depth of cut for semi-finishing $R \times ap0.13$

・仕上げの切込み量目安
Approximate depth of cut for finishing $R \times ap0.06$

フェニックス ディープフィーダーブルノーズ

Phoenix Deep Feeder Bull Nose

PHX-DFR

- 材質.....超微粒子超硬合金
Tool Material Micro Grain Carbide
- 表面処理.....WXスーパーコート(WXS)
Surface Treatment WX Super Coating
- ねじれ角.....55°
Helix Angle
- R許容差.....± 0.03mm
Radius Tolerance
- 外径許容差.....± 0.01mm
Milling Diameter Tolerance

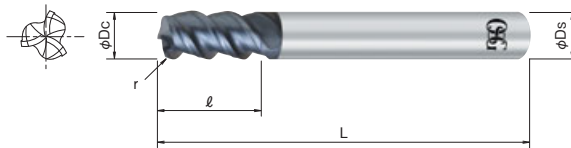

単位:mm Unit:mm

ツールNo. EDP No.	外径×コーナ半径 Dc × r	全長 L	刃長 ℓ	シャンク径 Ds	刃数 Z	在庫 Stock	標準価格 (Yen)
3090512	6 × R1.5	80	12	6	3	B	16,300
3090516	8 × R2	90	16	8	3	B	20,900
3090520	10 × R2	100	20	10	3	B	25,700
3090522	12 × R2	120	24	12	3	B	34,800
3090526	16 × R3	130	32	16	3	B	72,300
3090530	20 × R3	150	40	20	3	B	102,000

B = 在庫センター標準在庫品 B = Inventory center stock item.

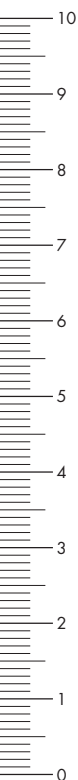

PHX-DFR



工具径や突き出し長さを確認
したい時にお使い下さい。
When needed, please use this
graph to confirm your tool
diameter and overhang length.

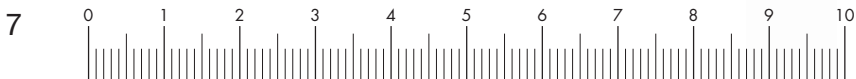

フェニックス ロングネックディープフィーダーブルノーズ

Phoenix Long Neck Deep Feeder Bull Nose

PHX-LN-DFR

- 材質.....超微粒子超硬合金
Tool Material Micro Grain Carbide
- 表面処理.....WXスーパーコート(WXS)
Surface Treatment WX Super Coating
- ねじれ角.....55°
Helix Angle
- R許容差.....± 0.03mm
Radius Tolerance
- 外径許容差.....± 0.01mm
Milling Diameter Tolerance

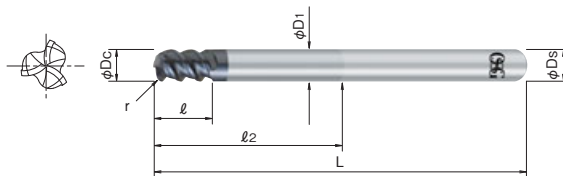

単位:mm Unit:mm

ツールNo. EDP No.	外径×コーナ半径×首下長 Dc × r × l ₂	全長 L	刃長 l	首径 D ₁	シャンク径 D _s	刃数 Z	在庫 Stock	標準価格 (Yen)
3092041	4 × R1 × 20	70	6	3.8	4	3	B	12,600
3092042	4 × R1 × 28	70	6	3.8	4	3	B	12,800
3092061	6 × R1.5 × 30	80	9	5.8	6	3	B	14,500
3092062	6 × R1.5 × 42	90	9	5.8	6	3	B	15,400
3092063	6 × R1.5 × 54	100	9	5.8	6	3	B	16,100
3092081	8 × R2 × 40	85	12	7.7	8	3	B	18,200
3092082	8 × R2 × 56	100	12	7.7	8	3	B	19,800
3092083	8 × R2 × 72	120	12	7.7	8	3	B	21,700
3092101	10 × R2 × 50	100	15	9.7	10	3	B	22,900
3092102	10 × R2 × 70	120	15	9.7	10	3	B	25,400
3092103	10 × R2 × 90	140	15	9.7	10	3	B	27,800
3092121	12 × R2 × 60	110	18	11.7	12	3	B	31,600
3092122	12 × R2 × 84	135	18	11.7	12	3	B	35,600
3092123	12 × R2 × 108	160	18	11.7	12	3	B	39,500
3092161	16 × R3 × 80	140	24	15.5	16	3	B	63,400
3092162	16 × R3 × 120	175	24	15.5	16	3	B	72,200

B = 在庫センター標準在庫品 B = Inventory center stock item.

フェニックス ペンシルネックディープフィーダブルノーズ

Phoenix Pencil Neck Deep Feeder Bull Nose

PHX-PC-DFR

- 材質.....超微粒子超硬合金
Tool Material Micro Grain Carbide
- 表面処理.....WXスーパーコート(WXS)
Surface Treatment WX Super Coating
- ねじれ角.....55°
Helix Angle
- R許容差.....± 0.03mm
Radius Tolerance
- 外径許容差.....0 ~ - 0.015mm
Milling Diameter Tolerance

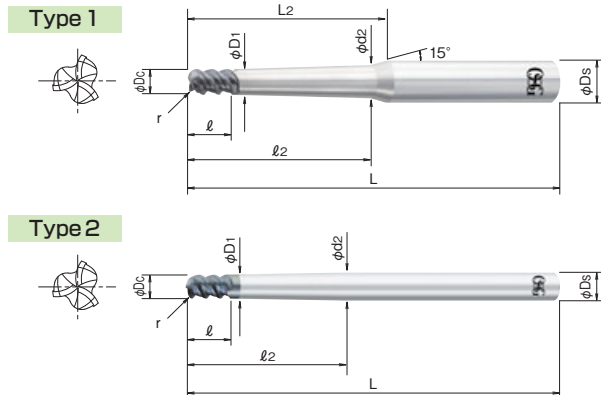

単位:mm Unit:mm

ツールNo. EDP No.	有効 勾配角 α	外径×コーナ半径×首部テーパ半角×首下長 $D_c \times r \times \theta_n \times \ell_z$	全長 L	刃長 ℓ	首径 D_1	首元径 d_2	刃先からシャンクまでの 有効長(参考値) L_2	シャンク径 D_s	刃数 Z	形状 Type	在庫 Stock	標準価格 (Yen)
3097223	0.36°	2 × R0.5 × 0.5° × 20	60	3	1.95	2.25	27.7	6	3	1	B	13,900
3097224	0.39°	2 × R0.5 × 0.5° × 25	70	3	1.95	2.33	32.6	6	3	1	B	14,100
3097225	0.41°	2 × R0.5 × 0.5° × 30	80	3	1.95	2.42	37.4	6	3	1	B	14,400
3097226	0.42°	2 × R0.5 × 0.5° × 35	80	3	1.95	2.51	42.2	6	3	1	B	15,700
3097227	0.43°	2 × R0.5 × 0.5° × 40	80	3	1.95	2.6	47.1	6	3	1	B	16,000
3097241	0.59°	2 × R0.5 × 1° × 10	60	3	1.95	2.19	17.8	6	3	1	B	13,200
3097242	0.73°	2 × R0.5 × 1° × 15	60	3	1.95	2.37	22.5	6	3	1	B	13,500
3097243	0.8°	2 × R0.5 × 1° × 20	60	3	1.95	2.54	27.1	6	3	1	B	13,900
3097244	0.84°	2 × R0.5 × 1° × 25	70	3	1.95	2.72	31.8	6	3	1	B	14,100
3097245	0.87°	2 × R0.5 × 1° × 30	80	3	1.95	2.89	36.5	6	3	1	B	14,400
3097246	0.89°	2 × R0.5 × 1° × 35	80	3	1.95	3.07	41.2	6	3	1	B	15,700
3097247	0.9°	2 × R0.5 × 1° × 40	80	3	1.95	3.24	45.8	6	3	1	B	16,000
3097248	0.91°	2 × R0.5 × 1° × 45	100	3	1.95	3.42	50.5	6	3	1	B	17,300
3097249	0.92°	2 × R0.5 × 1° × 50	100	3	1.95	3.59	55.2	6	3	1	B	17,600
3097251	1.37°	2 × R0.5 × 1.5° × 40	80	3	1.95	3.89	44.6	6	3	1	B	16,000
3097262	2°	2 × R0.5 × 2° × 60.3	100	3	1.95	6	—	6	3	2	B	18,200
3097273	3°	2 × R0.5 × 3° × 41.2	100	3	1.95	6	—	6	3	2	B	17,100
3097321	0.25°	3 × R0.8 × 0.5° × 20	80	4.5	2.9	3.17	26	6	3	1	B	13,600
3097341	0.66°	3 × R0.8 × 1° × 20	80	4.5	2.9	3.44	25.5	6	3	1	B	13,600
3097342	0.73°	3 × R0.8 × 1° × 25	80	4.5	2.9	3.62	30.1	6	3	1	B	13,900
3097343	0.78°	3 × R0.8 × 1° × 30	80	4.5	2.9	3.79	34.8	6	3	1	B	14,100
3097344	0.83°	3 × R0.8 × 1° × 40	80	4.5	2.9	4.14	44.2	6	3	1	B	14,400
3097345	0.87°	3 × R0.8 × 1° × 50	100	4.5	2.9	4.49	53.5	6	3	1	B	15,800
3097346	0.89°	3 × R0.8 × 1° × 60	100	4.5	2.9	4.84	62.9	6	3	1	B	16,100
3097356	1.5°	3 × R0.8 × 1.5° × 60.8	100	4.5	2.9	6	—	6	3	2	B	16,100
3097365	2°	3 × R0.8 × 2° × 46.5	100	4.5	2.9	6	—	6	3	2	B	15,700
3097374	3°	3 × R0.8 × 3° × 32.1	100	4.5	2.9	6	—	6	3	2	B	15,100
3097421	0.28°	4 × R1 × 0.5° × 25	80	6	3.9	4.23	29	6	3	1	B	14,100
3097422	0.31°	4 × R1 × 0.5° × 30	80	6	3.9	4.32	33.9	6	3	1	B	14,300
3097423	0.34°	4 × R1 × 0.5° × 35	80	6	3.9	4.41	38.7	6	3	1	B	14,400
3097424	0.36°	4 × R1 × 0.5° × 40	80	6	3.9	4.49	43.5	6	3	1	B	14,500
3097425	0.38°	4 × R1 × 0.5° × 45	80	6	3.9	4.58	48.4	6	3	1	B	14,700
3097426	0.39°	4 × R1 × 0.5° × 50	100	6	3.9	4.67	53.2	6	3	1	B	15,900
3097441	0.73°	4 × R1 × 1° × 30	80	6	3.9	4.74	33	6	3	1	B	14,300
3097442	0.8°	4 × R1 × 1° × 40	80	6	3.9	5.09	42.4	6	3	1	B	14,500
3097443	0.84°	4 × R1 × 1° × 50	100	6	3.9	5.44	51.8	6	3	1	B	15,900
3097444	1°	4 × R1 × 1° × 61.3	100	6	3.9	6	—	6	3	2	B	16,200
3097453	1.5°	4 × R1 × 1.5° × 42.2	80	6	3.9	6	—	6	3	2	B	14,600
3097454	1.5°	4 × R1 × 1.5° × 80.4	120	6	3.9	8	—	8	3	2	B	23,500
3097461	2°	4 × R1 × 2° × 32.6	80	6	3.9	6	—	6	3	2	B	14,400
3097462	2°	4 × R1 × 2° × 61.3	120	6	3.9	8	—	8	3	2	B	21,900
3097472	3°	4 × R1 × 3° × 42.2	100	6	3.9	8	—	8	3	2	B	19,000



次ページへ

B = 在庫センター標準在庫品 B = Inventory center stock item.

Type 1

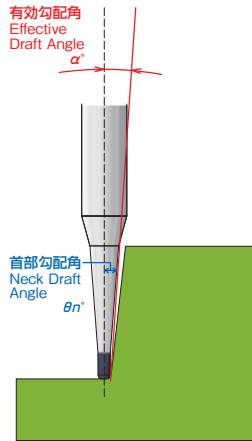

Type 2

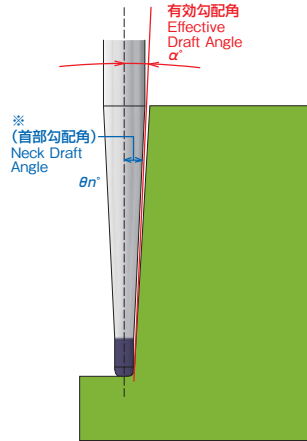

※切削状態によっては、工具がたわみ、勾配部が干渉する場合があります。

※ The tool may be deflected and may interfere with the draft area depending on milling condition.

※首部勾配角 (θn°) は便宜上有効勾配角 (α°) と同表記していますが、実際には異なります。(有効勾配角 (α°) に干渉しない角度にて設定)

※ For convenience, the Neck Draft Angle (θn°) is shown the same as the Effective Draft Angle (α°), but actually it is different. (It does not interfere with the Effective Draft Angle (α°))



前ページより

単位 :mm Unit:mm

ツールNo. EDP No.	有効 勾配角 α°	外径×コーナ半径×首部テーパ半角×首下長 $D_c \times r \times \theta n \times l_2$	全長 L	刃長 l	首径 D_1	首元径 d_2	刃先からシャンクまでの 有効長(参考値) L_2	シャンク径 D_s	刃数 Z	形状 Type	在庫 Stock	標準価格 (Yen)
3097627	0.39°	6 × R1.5 × 0.5° × 60	130	9	5.9	6.79	63	8	3	1	B	21,300
3097641	0.73°	6 × R1.5 × 1° × 40	100	9	5.9	6.98	42.6	8	3	1	B	18,200
3097642	0.79°	6 × R1.5 × 1° × 50	100	9	5.9	7.33	51.9	8	3	1	B	18,800
3097643	1°	6 × R1.5 × 1° × 62.3	130	9	5.9	8	—	8	3	2	B	21,300
3097651	1.5°	6 × R1.5 × 1.5° × 43.2	100	9	5.9	8	—	8	3	2	B	18,500
3097653	1.5°	6 × R1.5 × 1.5° × 81.4	130	9	5.9	10	—	10	3	2	B	27,300
3097661	2°	6 × R1.5 × 2° × 33.6	100	9	5.9	8	—	8	3	2	B	18,100
3097662	2°	6 × R1.5 × 2° × 62.3	130	9	5.9	10	—	10	3	2	B	25,900
3097826	0.4°	8 × R2 × 0.5° × 80	150	12	7.9	9.09	82.6	10	3	1	B	28,300
3097841	0.73°	8 × R2 × 1° × 50	120	12	7.9	9.23	52.3	10	3	1	B	24,300
3097842	1°	8 × R2 × 1° × 63.3	150	12	7.9	10	—	10	3	2	B	27,800
3097844	1°	8 × R2 × 1° × 120.6	180	12	7.9	12	—	12	3	2	B	42,800
3097851	1.5°	8 × R2 × 1.5° × 44.2	120	12	7.9	10	—	10	3	2	B	24,100
3097853	1.5°	8 × R2 × 1.5° × 82.4	150	12	7.9	12	—	12	3	2	B	36,100
3097861	2°	8 × R2 × 2° × 34.6	120	12	7.9	10	—	10	3	2	B	23,800
3097862	2°	8 × R2 × 2° × 63.3	120	12	7.9	12	—	12	3	2	B	31,000
3098026	0.4°	10 × R2 × 0.5° × 100	150	15	9.9	11.38	102	12	3	1	B	35,800
3098041	1°	10 × R2 × 1° × 64.3	120	15	9.9	12	—	12	3	2	B	30,200
3098042	0.8°	10 × R2 × 1° × 80	160	15	9.9	12.17	88	16	3	1	B	53,800
3098043	0.84°	10 × R2 × 1° × 100	160	15	9.9	12.87	106.7	16	3	1	B	56,700
3098044	0.87°	10 × R2 × 1° × 120	180	15	9.9	13.57	125.4	16	3	1	B	63,200
3098045	0.88°	10 × R2 × 1° × 140	200	15	9.9	14.26	144.1	16	3	1	B	70,000
3098046	0.9°	10 × R2 × 1° × 160	220	15	9.9	14.96	162.8	16	3	1	B	76,400
3098051	1.5°	10 × R2 × 1.5° × 45.2	120	15	9.9	12	—	12	3	2	B	29,200
3098053	1.5°	10 × R2 × 1.5° × 121.6	180	15	9.9	16	—	16	3	2	B	63,600
3098061	2°	10 × R2 × 2° × 35.6	120	15	9.9	12	—	12	3	2	B	28,600
3098064	2°	10 × R2 × 2° × 92.9	220	15	9.9	16	—	16	3	2	B	66,800
3098224	0.41°	12 × R2 × 0.5° × 120	180	18	11.9	13.68	125.2	16	3	1	B	63,400
3098241	0.67°	12 × R2 × 1° × 60	120	18	11.9	13.37	65.8	16	3	1	B	46,100
3098242	0.81°	12 × R2 × 1° × 100	180	18	11.9	14.76	103.2	16	3	1	B	61,000
3098243	1°	12 × R2 × 1° × 122.6	180	18	11.9	16	—	16	3	2	B	63,700
3098244	0.88°	12 × R2 × 1° × 160	220	18	11.9	16.86	166.7	20	3	1	B	105,000
3098254	1.5°	12 × R2 × 1.5° × 160.8	220	18	11.9	20	—	20	3	2	B	105,000

B = 在庫センター標準在庫品 B = Inventory center stock item.

フェニックス ハイフィーダーブルノーズ

Phoenix High-Feed Bull Nose End Mill

PHX-CRT



- **材質** 超微粒子超硬合金
Tool Material Micro Grain Carbide
- **表面処理** FX コーティング
Surface Treatment FX (TiAlN) Coating
- **ねじれ角** 55°
Helix Angle
- **R許容差** ± 0.01mm
Radius Tolerance
- **外径許容差** D ≤ 5 0 ~ - 0.015mm
Milling Diameter Tolerance D ≥ 6 0.01 ~ - 0.005mm

Type 1

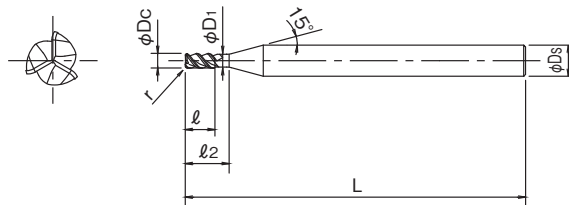

Type 2

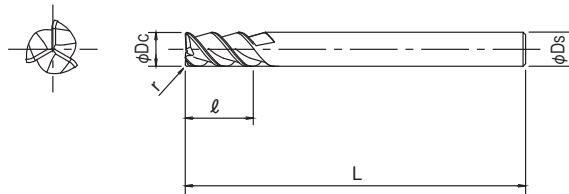

単位:mm Unit:mm

ツールNo. EDP No.	外径×コーナ半径 Dc × r	全長 L	刃長 l	シャンク径 Ds	首下長 l2	首径 D1	■ワーク勾配角αに対する実有効長(Le) ^{※1}				刃数 Z	形状 Type	在庫 Stock	標準価格 (Yen)
							0.5°	1°	2°	3°				
3090002	1 × R0.3	60	2	6	4	0.95	4.29	4.56	5.05	5.5	3	1	A	19,300
3090003	1.5 × R0.3	60	3	6	4.5	1.45	4.82	5.11	5.64	6.12	3	1	A	19,300
3090004	2 × R0.5	60	4	6	6	1.95	6.41	6.77	7.39	7.89	3	1	A	18,500
3090006	3 × R0.8	70	6	6	9	2.85	9.46	9.87	10.62	11.48	3	1	A	18,200
3090008	4 × R1	70	8	6	12	3.85	12.6	13.09	14.07	15.21	3	1	A	18,200
3090010	5 × R1	70	10	6	15	4.85	15.72	16.3	—	—	3	1	A	18,500
3090012	6 × R1.5	80	12	6	—	—	—	—	—	—	3	2	A	19,700
3090016	8 × R2	90	16	8	—	—	—	—	—	—	3	2	A	25,400
3090020	10 × R2	100	20	10	—	—	—	—	—	—	3	2	A	31,500
3090022	12 × R2	120	24	12	—	—	—	—	—	—	3	2	A	42,000
3090026	16 × R3	130	32	16	—	—	—	—	—	—	3	2	A	85,600
3090030	20 × R3	150	40	20	—	—	—	—	—	—	3	2	A	120,000

A = 標準在庫品 A = Standard stock item.

※1: ワーク勾配角αに対する実有効長(Le)
The effective Neck length (Le) depends on the Inclined Angle (α) of workpiece

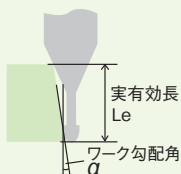

実有効長欄に数値のないものは
干渉なしを表します。
No numerical value means no
interference with workpiece.



PHX-CRT

フェニックス 高硬度リブ溝加工用タフラジオス

Phoenix Tough Radius For Rib Grooves

PHX-LN-CRE

●材質.....超微粒子超硬合金

Tool Material Micro Grain Carbide

●表面処理.....WXスーパーコート(WXS)

Surface Treatment WX Super Coating

●ねじれ角.....30°

Helix Angle

●R許容差.....± 0.007mm

Radius Tolerance

●外径許容差.....0 ~ - 0.01mm

Milling Diameter Tolerance

●首下長許容差.....0 ~ 0.1mm

Neck Length Tolerance

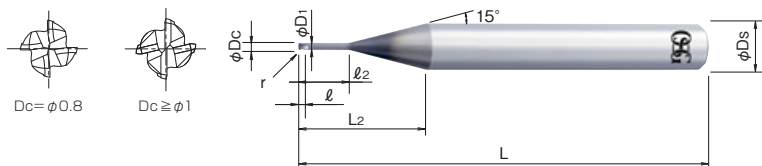

単位 :mm Unit:mm

ツールNo. EDP No.	外径×コーナ半径×首下長 Dc × r × L2	全長 L	刃長 ℓ	シャンク径 Ds	刃先からシャンクまでの 有効長(参考値) L2	首径 D1	■ワーク勾配角αに対する実有効長(Le) ^{※1}			刃数 Z	在庫 Stock	標準価格 (Yen)
							0°	0.5°	1°			
3190800	0.8 × R0.1 × 2	50	0.32	4	8.4	0.75	2	2.16	2.32	4	A	6,770
3190801	0.8 × R0.1 × 4	50	0.32	4	10.4	0.75	4	4.29	4.57	4	A	6,570
3190802	0.8 × R0.1 × 6	50	0.32	4	12.4	0.75	6	6.42	6.78	4	A	6,570
3190803	0.8 × R0.1 × 8	50	0.32	4	14.4	0.75	8	8.54	8.97	4	A	6,570
3191006	1 × R0.1 × 4	50	0.4	4	10.65	0.95	4	4.29	4.56	4	A	5,670
3191007	1 × R0.1 × 6	50	0.4	4	12.65	0.95	6	6.41	6.77	4	A	6,210
3191008	1 × R0.1 × 8	50	0.4	4	14.65	0.95	8	8.53	8.96	4	A	6,210
3191009	1 × R0.1 × 10	50	0.4	4	16.65	0.95	10	10.63	11.13	4	A	6,210
3191010	1 × R0.1 × 12	50	0.4	4	18.65	0.95	12	12.73	13.29	4	A	6,210
3191011	1 × R0.2 × 4	50	0.4	4	10.65	0.95	4	4.29	4.56	4	A	5,670
3191012	1 × R0.2 × 6	50	0.4	4	12.65	0.95	6	6.41	6.77	4	A	6,210
3191013	1 × R0.2 × 8	50	0.4	4	14.65	0.95	8	8.53	8.96	4	A	6,210
3191014	1 × R0.2 × 10	50	0.4	4	16.65	0.95	10	10.63	11.13	4	A	6,210
3191015	1 × R0.2 × 12	50	0.4	4	18.65	0.95	12	12.73	13.29	4	A	6,210
3191018	1 × R0.3 × 4	50	0.4	4	10.65	0.95	4	4.29	4.56	4	A	5,670
3191019	1 × R0.3 × 6	50	0.4	4	12.65	0.95	6	6.41	6.77	4	A	6,210
3191501	1.5 × R0.1 × 4	50	0.6	4	9.07	1.45	4	4.29	4.56	4	A	6,040
3191503	1.5 × R0.1 × 8	50	0.6	4	13.07	1.45	8	8.53	8.96	4	A	6,370
3191505	1.5 × R0.1 × 12	50	0.6	4	17.07	1.45	12	12.73	13.29	4	A	6,370
3191506	1.5 × R0.2 × 4	50	0.6	4	9.07	1.45	4	4.29	4.56	4	A	6,040
3191507	1.5 × R0.2 × 6	50	0.6	4	11.07	1.45	6	6.41	6.77	4	A	6,040
3191508	1.5 × R0.2 × 8	50	0.6	4	13.07	1.45	8	8.53	8.96	4	A	6,370
3192001	2 × R0.1 × 8	50	0.8	4	10.48	1.95	8	8.53	8.96	4	A	6,370
3192002	2 × R0.1 × 10	50	0.8	4	14.35	1.95	10	10.63	11.13	4	A	6,370
3192003	2 × R0.1 × 12	50	0.8	4	16.35	1.95	12	12.73	13.29	4	A	6,370
3192004	2 × R0.1 × 16	50	0.8	4	20.35	1.95	16	16.92	17.57	4	A	6,370
3192013	2 × R0.3 × 8	50	0.8	4	12.35	1.95	8	8.53	8.96	4	A	6,370
3192015	2 × R0.3 × 12	50	0.8	4	16.35	1.95	12	12.73	13.29	4	A	6,370
3192019	2 × R0.5 × 6	50	0.8	4	10.35	1.95	6	6.41	6.77	4	A	6,040
3192020	2 × R0.5 × 8	50	0.8	4	12.35	1.95	8	8.53	8.96	4	A	6,370
3192021	2 × R0.5 × 10	50	0.8	4	14.35	1.95	10	10.63	11.13	4	A	6,370
3192022	2 × R0.5 × 12	50	0.8	4	16.35	1.95	12	12.73	13.29	4	A	6,370
3193008	3 × R0.3 × 12	50	1.2	4	18.05	2.85	12	12.73	13.29	4	A	6,570

※1:ワーク勾配角αに対する実有効長(Le)

The effective Neck length (Le) depends on the Inclined Angle (α) of workpiece

A = 標準在庫品 A = Standard stock item.

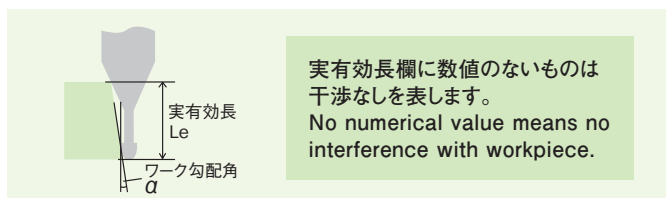

フェニックス ディープフィーダーボール

Phoenix Deep-Feed Ball Nose End Mill

PAT.(JP・US・EP・CN・KR)

PHX-DBT



- 材質.....超微粒子超硬合金
Tool Material Micro Grain Carbide
- 表面処理.....FX コーティング
Surface Treatment FX (TiAlN) Coating
- ねじれ角.....45°
Helix Angle
- R許容差.....± 0.01mm
Radius Tolerance
- 外径許容差.....D ≤ 5 0 ~ - 0.015mm
D ≥ 6 0.01 ~ - 0.005mm
Milling Diameter Tolerance

Type 1

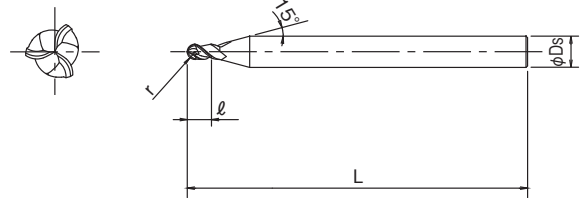

Type 2

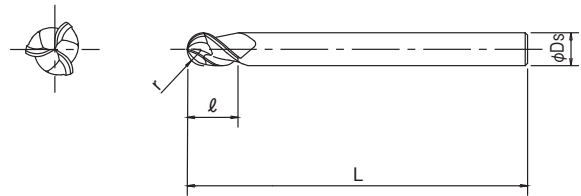

単位:mm Unit:mm

ツールNo. EDP No.	ボール半径×全長 R×L	刃長 ℓ	シャンク径 Ds	刃数 Z	形状 Type	在庫 Stock	標準価格 (Yen)
3090202	R 0.5 × 60	1.5	6	3	1	A	15,600
3090204	R 1 × 60	3	6	3	1	A	15,600
3090206	R 1.5 × 70	4.5	6	3	1	A	17,000
3090208	R 2 × 70	6	6	3	1	A	17,000
3090210	R 2.5 × 70	7.5	6	3	1	A	17,800
3090212	R 3 × 80	9	6	3	2	A	18,200
3090312	R 3 × 110	9	6	3	2	A	19,300
3090216	R 4 × 90	12	8	3	2	A	24,100
3090316	R 4 × 120	12	8	3	2	A	25,200
3090220	R 5 × 100	15	10	3	2	A	32,900
3090320	R 5 × 130	15	10	3	2	A	35,300
3090222	R 6 × 100	18	12	3	2	A	42,800
3090322	R 6 × 140	18	12	3	2	A	46,800
3090226	R 8 × 150	24	16	3	2	A	72,800
3090230	R 10 × 150	30	20	3	2	A	114,000
3090330	R 10 × 200	30	20	3	2	A	125,000

A = 標準在庫品 A = Standard stock item.



PHX-DBT

フェニックス ロングネックボール

Phoenix Long Neck Ball Nose End Mill

NEW

PHX-LN-DBT

2013年3月発売予定
Available from March 2013.



- 材質.....超微粒子超硬合金
Tool Material Micro Grain Carbide
- 表面処理.....WXスーパーコート(WXS)
Surface Treatment WX Super Coating
- ねじれ角.....45°
Helix Angle
- R許容差.....± 0.007mm
Radius Tolerance
- 外径許容差.....± 0.007mm
Milling Diameter Tolerance

Type 1

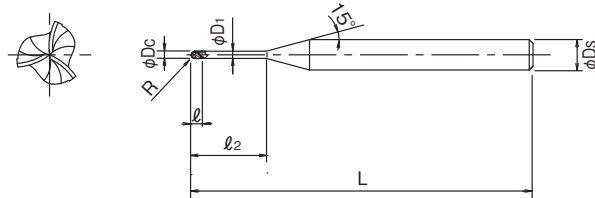

Type 2

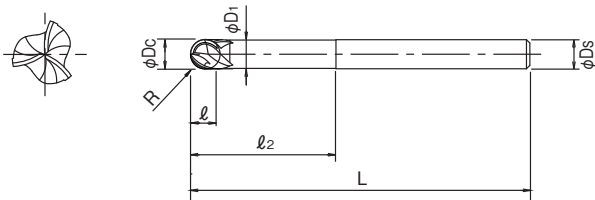

単位 :mm Unit:mm

ツールNo. EDP No.	ボール半径 x 首下長 R × l ₂	全長 L	刃長 l	シャンク径 Ds	首径 D ₁	干渉角度	■ワーク勾配角αに対する実有効長 (Le) ^{*1}						在庫 Stock	標準価格 (Yen)
							0.5°	1°	1.5°	2°	2.5°	3°		
3195004	R0.5 × 4	50	0.75	4	0.95	8.51	4.26	4.5	4.74	4.96	5.18	5.39	B	3,480
3195006	R0.5 × 6	50	0.75	4	0.95	7.13	6.39	6.72	7.03	7.32	7.95	7.88	B	3,740
3195008	R0.5 × 8	50	0.75	4	0.95	6.12	8.5	8.92	9.28	9.62	9.98	10.36	B	3,740
3195010	R0.5 × 10	50	0.75	4	0.95	5.35	10.61	11.09	11.51	11.92	12.37	12.85	B	3,740
3195012	R0.5 × 12	50	0.75	4	0.95	4.76	12.71	13.25	13.71	14.12	14.49	14.83	B	3,740
3195014	R0.5 × 14	50	0.75	4	0.95	4.3	14.81	15.4	15.9	16.34	16.73	17.82	B	4,410
3195016	R0.5 × 16	50	0.75	4	0.95	3.9	16.9	17.54	18.07	18.54	19.53	20.31	B	5,160
3195106	R0.75 × 6	50	1.12	4	1.45	6.43	6.37	6.7	7	7.28	7.54	7.82	B	3,560
3195108	R0.75 × 8	50	1.12	4	1.45	5.46	8.49	8.89	9.25	9.58	9.93	10.3	B	3,740
3195110	R0.75 × 10	50	1.12	4	1.45	4.75	10.6	11.07	11.48	11.88	12.32	12.79	B	4,070
3195112	R0.75 × 12	50	1.12	4	1.45	4.19	12.7	13.23	13.69	14.09	14.46	14.8	B	4,410
3195116	R0.75 × 16	50	1.12	4	1.45	3.4	16.89	17.52	18.05	18.51	18.93	19.31	B	4,410
3195206	R1 × 6	50	1.5	4	1.95	5.62	6.35	6.65	6.94	7.21	7.46	7.73	B	3,480
3195208	R1 × 8	50	1.5	4	1.95	4.71	8.46	8.85	9.2	9.52	9.85	10.21	B	3,740
3195210	R1 × 10	50	1.5	4	1.95	4.04	10.57	11.03	11.43	11.82	12.24	12.7	B	3,740
3195212	R1 × 12	50	1.5	4	1.95	3.55	12.67	13.19	13.64	14.12	14.63	15.19	B	3,740
3195214	R1 × 14	50	1.5	4	1.95	3.16	14.77	15.34	15.86	16.42	17.02	17.67	B	3,740
3195216	R1 × 16	50	1.5	4	1.95	2.84	16.86	17.48	18.08	18.72	19.41	—	B	3,740
3195218	R1 × 18	60	1.5	4	1.95	2.59	18.94	19.62	20.29	21.02	21.8	—	B	3,740
3195220	R1 × 20	60	1.5	4	1.95	2.37	21.03	21.76	22.51	23.18	—	—	B	3,740
3195222	R1 × 22	60	1.5	4	1.95	2.19	23.13	23.89	24.5	25.03	—	—	B	5,160
3195312	R1.5 × 12	60	2.25	4	2.85	2.04	12.61	13.1	13.57	14.08	—	—	B	4,330
3195316	R1.5 × 16	60	2.25	4	2.85	1.59	16.77	17.38	17.01	—	—	—	B	5,090
3195320	R1.5 × 20	60	2.25	4	2.85	1.3	20.92	21.65	—	—	—	—	B	4,920
3195325	R1.5 × 25	60	2.25	4	2.85	1.06	26.1	—	—	—	—	—	B	4,920
3195416	R2 × 16	60	3	4	3.85	—	—	—	—	—	—	—	B	5,090
3195420	R2 × 20	60	3	4	3.85	—	—	—	—	—	—	—	B	5,090
3195425	R2 × 25	60	3	4	3.85	—	—	—	—	—	—	—	B	5,090
3195520	R3 × 20	70	4.5	6	5.85	—	—	—	—	—	—	—	B	6,360
3195530	R3 × 30	70	4.5	6	5.85	—	—	—	—	—	—	—	B	6,520

*1: ワーク勾配角αに対する実有効長 (Le)

The effective Neck length (Le) depends on the Inclined Angle (α) of workpiece

B = 標準在庫品 B = Standard stock item.

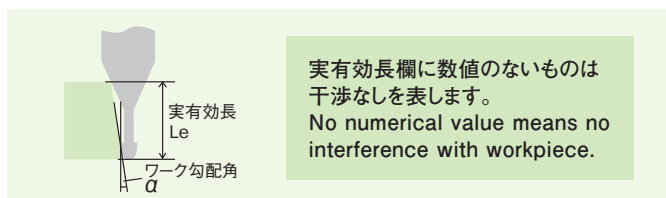

Deep-Feed Ball Nose Series
ディープフィードボールノーズシリーズ

フェニックス ペンシルネックディープフィーダーボール

Phoenix Pencil-Neck Deep-Feed Ball Nose End Mill

PHX-PC-DBT

- 材質.....超微粒子超硬合金
Tool Material Micro Grain Carbide
- 表面処理.....WXスーパーコート(WXS)
Surface Treatment WX Super Coating
- ねじれ角.....45°
Helix Angle
- R許容差.....± 0.01mm
Radius Tolerance
- 外径許容差.....0 ~ - 0.015mm
Milling Diameter Tolerance

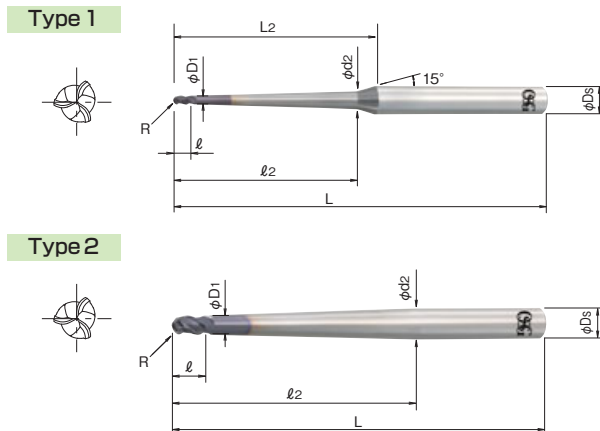

単位:mm Unit:mm

ツールNo. EDP No.	有効勾配角 α	ボール半径×首部テーパ半角×首下長 $R \times \theta \times n \times \ell_2$	全長 L	刃長 ℓ	首径 D_1	首元径 d_2	刃先からシャンクまでの有効長(参考値) L_2	シャンク径 D_s	形状 Type	在庫 Stock	標準価格 (Yen)
3095125	0.38°	R0.5 × 0.5° × 16	60	1.5	0.95	1.2	25.7	6	1	A	12,000
3095141	0.56°	R0.5 × 1° × 6	60	1.5	0.95	1.1	15.8	6	1	A	11,700
3095142	0.68°	R0.5 × 1° × 8	60	1.5	0.95	1.17	17.7	6	1	A	11,800
3095143	0.75°	R0.5 × 1° × 10	60	1.5	0.95	1.24	19.6	6	1	A	11,800
3095144	0.79°	R0.5 × 1° × 12	60	1.5	0.95	1.31	21.5	6	1	A	11,900
3095145	0.85°	R0.5 × 1° × 16	60	1.5	0.95	1.45	25.2	6	1	A	12,000
3095146	0.88°	R0.5 × 1° × 20	60	1.5	0.95	1.59	28.9	6	1	A	12,100
3095147	0.91°	R0.5 × 1° × 25	70	1.5	0.95	1.77	33.6	6	1	A	12,800
3095155	1.3°	R0.5 × 1.5° × 15	60	1.5	0.95	1.65	23.8	6	1	A	12,000
3095157	1.39°	R0.5 × 1.5° × 25	70	1.5	0.95	2.18	32.8	6	1	A	12,800
3095191	4.3°	R0.5 × 4.5° × 30	70	1.5	0.95	5.43	31.7	6	1	A	13,000
3095211	0.45°	R0.75 × 1° × 6	60	2.25	1.45	1.58	14.9	6	1	A	11,700
3095212	0.65°	R0.75 × 1° × 9	60	2.25	1.45	1.68	17.7	6	1	A	11,800
3095213	0.74°	R0.75 × 1° × 12	60	2.25	1.45	1.79	20.5	6	1	A	11,900
3095214	0.8°	R0.75 × 1° × 15	60	2.25	1.45	1.89	23.3	6	1	A	12,000
3095215	0.86°	R0.75 × 1° × 21	60	2.25	1.45	2.1	28.9	6	1	A	12,100
3095216	0.9°	R0.75 × 1° × 30	70	2.25	1.45	2.41	37.4	6	1	A	13,000
3095223	0.38°	R1 × 0.5° × 20	60	3	1.95	2.24	27.7	6	1	A	12,100
3095241	0.62°	R1 × 1° × 10	60	3	1.95	2.19	17.8	6	1	A	11,800
3095242	0.76°	R1 × 1° × 15	60	3	1.95	2.36	22.5	6	1	A	12,000
3095243	0.82°	R1 × 1° × 20	60	3	1.95	2.54	27.1	6	1	A	12,100
3095244	0.86°	R1 × 1° × 25	70	3	1.95	2.71	31.8	6	1	A	12,800
3095245	0.89°	R1 × 1° × 30	80	3	1.95	2.89	36.5	6	1	A	13,500
3095246	0.92°	R1 × 1° × 40	80	3	1.95	3.24	45.8	6	1	A	13,900
3095247	0.93°	R1 × 1° × 50	100	3	1.95	3.59	55.2	6	1	A	15,100
3095251	1.39°	R1 × 1.5° × 40	80	3	1.95	3.88	44.6	6	1	A	15,400
3095262	2°	R1 × 2° × 60.3	100	3	1.95	6	—	6	2	A	17,000
3095273	3°	R1 × 3° × 41.2	80	3	1.95	6	—	6	2	A	15,400
3095281	3.8°	R1 × 3.8° × 30	80	3	1.95	6	—	6	2	A	15,000
3095321	0.27°	R1.5 × 0.5° × 20	80	4.5	2.9	3.17	26	6	1	A	14,700
3095341	0.69°	R1.5 × 1° × 20	80	4.5	2.9	3.44	25.5	6	1	A	14,700
3095342	0.76°	R1.5 × 1° × 25	80	4.5	2.9	3.61	30.1	6	1	A	14,800
3095343	0.8°	R1.5 × 1° × 30	80	4.5	2.9	3.79	34.8	6	1	A	15,000
3095344	0.85°	R1.5 × 1° × 40	80	4.5	2.9	4.13	44.2	6	1	A	15,400
3095345	0.88°	R1.5 × 1° × 50	100	4.5	2.9	4.48	53.5	6	1	A	16,700
3095346	0.9°	R1.5 × 1° × 60	100	4.5	2.9	4.83	62.9	6	1	A	17,000
3095356	1.5°	R1.5 × 1.5° × 60.8	100	4.5	2.9	6	—	6	2	A	17,100
3095365	2°	R1.5 × 2° × 46.5	100	4.5	2.9	6	—	6	2	A	16,600
3095374	3°	R1.5 × 3° × 32.1	80	4.5	2.9	6	—	6	2	A	15,100
3095421	0.29°	R2 × 0.5° × 25	80	6	3.9	4.23	29	6	1	A	14,800
3095441	0.76°	R2 × 1° × 30	80	6	3.9	4.73	33	6	1	A	15,000
3095442	0.82°	R2 × 1° × 40	80	6	3.9	5.08	42.4	6	1	A	15,400

A = 標準在庫品 A = Standard stock item.



次ページへ

Type 1

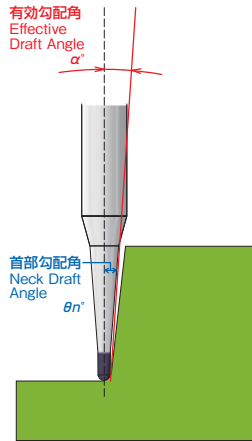

Type 2

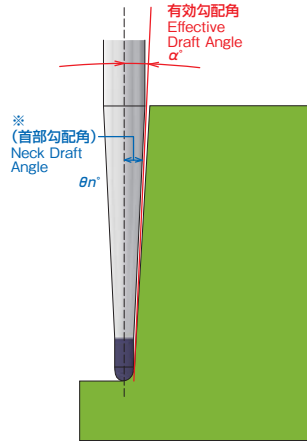

※切削状態によっては、工具がたわみ、勾配部が干渉する場合があります。

※ The tool may be deflected and may interfere with the draft area depending on milling condition.

※首部勾配角 (θn°) は便宜上有効勾配角 (α°) と同表記していますが、実際には異なります。(有効勾配角 (α°) に干渉しない角度にて設定)

※ For convenience, the Neck Draft Angle (θn°) is shown the same as the Effective Draft Angle (α°), but actually it is different. (It does not interfere with the Effective Draft Angle (α°))



前ページより

単位:mm Unit:mm

ツールNo. EDP No.	有効勾配角 α	ボール半径×首部テーパ半角×首下長 $R \times \theta n \times L_2$	全長 L	刃長 ℓ	首径 D_1	首元径 d_2	刃先からシャンクまでの有効長(参考値) L_2	シャンク径 D_s	形状 Type	在庫 Stock	標準価格 (Yen)
3095443	0.86°	R2 × 1° × 50	100	6	3.9	5.43	51.8	6	1	A	16,700
3095444	1°	R2 × 1° × 61.3	100	6	3.9	6	—	6	2	A	17,100
3095445	0.92°	R2 × 1° × 80	120	6	3.9	6.48	83.5	8	1	A	20,900
3095453	1.5°	R2 × 1.5° × 42.2	80	6	3.9	6	—	6	2	A	15,400
3095454	1.5°	R2 × 1.5° × 80.4	120	6	3.9	8	—	8	2	A	20,900
3095462	2°	R2 × 2° × 61.3	120	6	3.9	8	—	8	2	A	20,400
3095472	3°	R2 × 3° × 42.2	100	6	3.9	8	—	8	2	A	18,200
3095541	0.76°	R2.5 × 1° × 35	100	7.5	4.9	5.86	39.7	8	1	A	18,700
3095542	0.84°	R2.5 × 1° × 50	100	7.5	4.9	6.38	53.7	8	1	A	19,200
3095543	0.89°	R2.5 × 1° × 70	130	7.5	4.9	7.08	72.4	8	1	A	21,900
3095544	1°	R2.5 × 1° × 90.4	130	7.5	4.9	8	—	8	2	A	22,500
3095553	1.5°	R2.5 × 1.5° × 61.8	130	7.5	4.9	8	—	8	2	A	21,700
3095562	2°	R2.5 × 2° × 47.5	130	7.5	4.9	8	—	8	2	A	21,300
3095641	0.77°	R3 × 1° × 40	100	9	5.9	6.98	42.6	8	1	A	20,300
3095642	0.82°	R3 × 1° × 50	100	9	5.9	7.33	51.9	8	1	A	20,600
3095643	1°	R3 × 1° × 62.3	130	9	5.9	8	—	8	2	A	22,900
3095644	0.9°	R3 × 1° × 90	130	9	5.9	8.72	93.1	10	1	A	27,000
3095651	1.5°	R3 × 1.5° × 43.2	100	9	5.9	8	—	8	2	A	20,400
3095653	1.5°	R3 × 1.5° × 81.4	130	9	5.9	10	—	10	2	A	26,500
3095661	2°	R3 × 2° × 33.6	100	9	5.9	8	—	8	2	A	20,100
3095662	2°	R3 × 2° × 62.3	130	9	5.9	10	—	10	2	A	25,900
3095841	0.77°	R4 × 1° × 50	120	12	7.9	9.22	52.3	10	1	A	26,500
3095842	1°	R4 × 1° × 63.3	120	12	7.9	10	—	10	2	A	27,000
3095843	0.88°	R4 × 1° × 90	150	12	7.9	10.62	93.4	12	1	A	34,800
3095844	1°	R4 × 1° × 120.6	180	12	7.9	12	—	12	2	A	39,500
3095851	1.5°	R4 × 1.5° × 44.2	120	12	7.9	10	—	10	2	A	26,300
3095853	1.5°	R4 × 1.5° × 82.4	150	12	7.9	12	—	12	2	A	34,700
3095862	2°	R4 × 2° × 63.3	120	12	7.9	12	—	12	2	A	31,800
3096041	1°	R5 × 1° × 64.3	120	15	9.9	12	—	12	2	A	36,400
3096042	0.83°	R5 × 1° × 80	160	15	9.9	12.16	88	16	1	A	53,400
3096043	0.87°	R5 × 1° × 100	160	15	9.9	12.86	106.7	16	1	A	54,000
3096044	0.89°	R5 × 1° × 120	180	15	9.9	13.56	125.4	16	1	A	58,400
3096045	0.91°	R5 × 1° × 140	200	15	9.9	14.26	144.1	16	1	A	63,100
3096046	0.92°	R5 × 1° × 160	220	15	9.9	14.96	162.8	16	1	A	67,500
3096051	1.5°	R5 × 1.5° × 45.2	120	15	9.9	12	—	12	2	A	35,900
3096053	1.5°	R5 × 1.5° × 121.6	180	15	9.9	16	—	16	2	A	58,400
3096061	2°	R5 × 2° × 35.6	120	15	9.9	12	—	12	2	A	35,600
3096064	2°	R5 × 2° × 92.9	160	15	9.9	16	—	16	2	A	53,800
3096241	0.73°	R6 × 1° × 60	120	18	11.9	13.36	65.8	16	1	A	51,300
3096242	0.85°	R6 × 1° × 100	180	18	11.9	14.76	103.2	16	1	A	64,200
3096243	1°	R6 × 1° × 122.6	180	18	11.9	16	—	16	2	A	65,000
3096244	0.91°	R6 × 1° × 160	220	18	11.9	16.85	166.7	20	1	A	94,200
3096254	1.5°	R6 × 1.5° × 160.8	220	18	11.9	20	—	20	2	A	94,200

A = 標準在庫品 A = Standard stock item.

■ PHX-DFR/PHX-LN-DFR/PHX-PC-DFR/PHX-CRT 切削条件基準表 Recommended Milling Conditions

下記は代表的な材質を掲載しております。その他の材質につきましては、当社HPの「技術情報」を参照下さい。

Below is a sampling of materials. For other materials, please refer to the "Technical Information" section of our Web site.

被削材 WORK MATERIAL		快削材 高能率取り条件 ~38HRC Free-machining materials Cutting conditions for high efficiency roughing						高じん性金型材 中荒取り条件 38~53HRC High toughness mold materials Cutting conditions for semi-roughing (びびり抑制条件) Vibration control conditions				仕上げ加工条件 ~55HRC Machining conditions for finishing (びびり抑制条件) Vibration control conditions				
		調質鋼・プリハードン鋼 HARDENED STEELS・PREHARDENED STEELS														
		SKT4・SKD61・NAK80・HPM1・DH**						DH**・DAC55				SKT4・SKD61・NAK80・HPM1・DH**				
		外径 Dc	r	突き出し量 L/D	推奨傾斜 切込角度 Recommended Cutting Angle	回転速度 SPEED (min ⁻¹)	送り速度 FEED (mm/min)	切込深さ(mm) DEPTH OF CUT		回転速度 SPEED (min ⁻¹)	送り速度 FEED (mm/min)	切込深さ(mm) DEPTH OF CUT		回転速度 SPEED (min ⁻¹)	送り速度 FEED (mm/min)	切込深さ(mm) DEPTH OF CUT
ap	ae							ap	ae			ap	ae			
1	R0.3	10	0.3°	16,000	900	0.03	0.14	16,000	900	0.03	0.14	16,000	900	0.04	0.14	0.05
		15		8,000	450	0.03	0.14	8,000	450	0.02	0.14	8,000	450	0.04	0.14	0.05
		20		6,000	350	0.02	0.14	6,000	350	0.02	0.14	6,000	350	0.04	0.14	0.03
		25		6,000	300	0.01	0.13	6,000	300	0.01	0.13	6,000	300	0.04	0.14	0.03
		30		6,000	250	0.01	0.12	6,000	250	0.01	0.12	6,000	250	0.04	0.14	0.03
1.5	R0.3	10	0.3°	16,000	1,400	0.05	0.3	16,000	1,200	0.05	0.3	16,000	1,400	0.04	0.35	0.07
		15		8,000	800	0.05	0.3	8,000	600	0.05	0.3	8,000	800	0.04	0.35	0.05
		20		5,500	550	0.04	0.3	5,500	500	0.04	0.3	5,500	550	0.04	0.35	0.05
		25		5,000	500	0.04	0.3	5,000	450	0.04	0.3	5,000	500	0.04	0.35	0.03
		30		4,500	450	0.04	0.3	4,500	400	0.04	0.3	4,500	450	0.04	0.35	0.03
2	R0.5	10	0.3°	12,000	1,450	0.15	0.4	12,000	1,100	0.15	0.4	12,000	1,100	0.06	0.4	0.07
		15		7,800	900	0.12	0.4	7,800	700	0.1	0.4	7,800	700	0.06	0.4	0.07
		20		6,200	750	0.1	0.3	6,200	600	0.07	0.3	6,200	600	0.06	0.4	0.05
		25		4,700	550	0.07	0.3	4,700	500	0.06	0.3	4,700	500	0.06	0.4	0.05
		30		3,500	400	0.07	0.3	3,500	400	0.05	0.3	3,500	400	0.06	0.4	0.05
		35		3,500	400	0.07	0.2	3,500	400	0.04	0.2	3,500	400	0.06	0.4	0.03
		40		3,500	300	0.07	0.2	3,500	300	0.04	0.2	3,500	300	0.06	0.4	0.03
		45		3,500	200	0.07	0.2	3,500	200	0.03	0.2	3,500	200	0.06	0.4	0.03
		50		3,500	150	0.06	0.1	3,500	150	0.03	0.1	3,500	200	0.06	0.4	0.03
60	3,500	150	0.05	0.1	3,500	150	0.03	0.1	3,500	200	0.06	0.4	0.03			
3	R0.8	10	0.3°	11,000	1,650	0.13	0.6	8,000	1,200	0.13	0.6	11,000	2,100	0.1	0.5	0.1
		15		10,000	1,500	0.13	0.6	8,000	1,200	0.13	0.6	10,000	1,900	0.1	0.5	0.07
		20		7,500	1,100	0.12	0.5	7,200	1,000	0.12	0.5	7,500	1,400	0.1	0.5	0.07
		25		4,800	700	0.12	0.4	4,600	650	0.12	0.4	4,800	900	0.1	0.5	0.05
		30		3,800	550	0.1	0.4	3,400	500	0.1	0.4	3,800	750	0.1	0.5	0.03
		40		2,600	450	0.08	0.3	2,600	400	0.08	0.3	2,600	550	0.1	0.5	0.03
		50		2,200	350	0.06	0.3	2,200	300	0.06	0.3	2,200	450	0.1	0.5	0.03
		60		2,200	350	0.04	0.3	2,200	300	0.04	0.3	2,200	450	0.1	0.5	0.03
4	R1	10	0.5°	9,500	2,100	0.2	0.9	6,000	1,250	0.2	0.9	9,500	2,250	0.12	0.8	0.1
		15		9,000	2,000	0.2	0.8	6,000	1,250	0.2	0.8	9,000	2,150	0.12	0.8	0.1
		20		8,200	1,700	0.2	0.7	6,000	1,250	0.14	0.7	8,200	2,000	0.12	0.7	0.1
		25		5,500	1,400	0.15	0.7	5,500	1,150	0.11	0.7	5,500	1,350	0.12	0.7	0.07
		30		4,500	1,150	0.15	0.7	4,500	900	0.09	0.7	4,500	1,100	0.12	0.7	0.07
		35		3,600	1,100	0.12	0.6	3,600	750	0.09	0.6	3,600	900	0.12	0.7	0.05
		40		3,000	900	0.12	0.6	3,000	650	0.09	0.6	3,000	800	0.12	0.7	0.05
		45		2,700	850	0.1	0.5	2,700	600	0.08	0.5	2,700	750	0.12	0.7	0.03
		50		2,500	800	0.1	0.5	2,500	550	0.08	0.5	2,500	600	0.12	0.7	0.03
60	2,100	700	0.08	0.5	2,100	450	0.06	0.5	2,100	500	0.12	0.7	0.03			
5	R1	10	0.5°	7,700	2,500	0.2	1.2	4,800	3,600	0.2	1.2	7,700	1,800	0.12	1.2	0.1
		15		7,700	2,400	0.2	1.2	4,800	3,400	0.16	1.2	6,100	1,450	0.12	1.2	0.1
		20		7,700	2,400	0.2	1.2	4,800	3,400	0.16	1.2	6,100	1,450	0.12	1.2	0.1
		25		5,100	2,200	0.17	1	4,800	3,000	0.13	1	5,100	1,200	0.12	1.2	0.07
		30		5,100	2,200	0.17	1	4,800	3,000	0.13	1	5,100	1,200	0.12	1.2	0.07
		35		4,400	1,700	0.15	1	4,400	2,400	0.09	1	4,400	1,000	0.12	1.2	0.05
		40		3,100	1,100	0.15	1	3,100	1,500	0.08	1	3,100	750	0.12	1.2	0.05
6	R1.5	24	0.5°	6,500	2,100	0.35	1.3	4,000	1,700	0.24	1.3	6,500	1,900	0.15	1.2	0.1
		30		5,100	2,000	0.24	1.2	4,000	1,700	0.23	1.2	5,100	1,500	0.15	1.2	0.1
		36		4,200	1,800	0.2	1	4,000	1,700	0.19	1	4,200	1,250	0.15	1.2	0.07
		42		3,700	1,500	0.15	1	3,700	1,400	0.14	1	3,700	1,100	0.15	1.2	0.07
		48		2,600	1,000	0.13	0.9	2,600	900	0.14	0.9	2,600	800	0.15	1.2	0.05
		54		2,100	800	0.1	0.9	2,100	800	0.1	0.9	2,100	650	0.15	1.2	0.05
		66		1,900	700	0.08	0.9	1,900	700	0.08	0.9	1,900	550	0.15	1.2	0.03
		80		1,700	600	0.05	0.9	1,700	600	0.05	0.9	1,700	450	0.15	1.2	0.03



次ページへ



前ページより

被削材 WORK MATERIAL		快削材 高効率荒取り条件 ~38HRC Free-machining materials Cutting conditions for high efficiency roughing						高じん性金型材 中荒取り条件 38~53HRC High toughness mold materials Cutting conditions for semi-roughing (びびり抑制条件) Vibration control conditions				仕上げ加工条件 ~55HRC Machining conditions for finishing (びびり抑制条件) Vibration control conditions				
		調質鋼・プリハードン鋼 HARDENED STEELS · PREHARDENED STEELS												仕上げ代 (mm) CLEARANCE		
		SKT4 · SKD61 · NAK80 · HPM1 · DH**						DH** · DAC55				SKT4 · SKD61 · NAK80 · HPM1 · DH**				
外径 Dc	r	突き出し 量 L/D	推奨傾斜 切込角度 Recommended Cutting Angle	回転速度 SPEED (min ⁻¹)		送り速度 FEED (mm/min)		切込深さ(mm) DEPTH OF CUT		回転速度 SPEED (min ⁻¹)		送り速度 FEED (mm/min)		切込深さ(mm) DEPTH OF CUT		仕上げ代 (mm) CLEARANCE
				a_p	a_e	a_p	a_e	a_p	a_e	a_p	a_e					
8	R2	0.5°	30	4,800	2,000	0.5	1.7	3,000	1,250	0.3	1.6	4,800	1,800	0.18	1.6	0.1
			40	3,800	1,900	0.4	1.6	3,000	1,250	0.3	1.6	3,800	1,400	0.18	1.6	0.1
			48	3,200	1,700	0.27	1.4	3,000	1,250	0.26	1.4	3,200	1,150	0.18	1.6	0.07
			56	2,700	1,300	0.2	1.4	2,700	1,100	0.2	1.4	2,700	1,000	0.18	1.6	0.07
			64	1,900	880	0.2	1.3	1,900	800	0.2	1.3	1,900	700	0.18	1.6	0.05
			80	1,500	700	0.15	1.3	1,500	700	0.15	1.3	1,500	550	0.18	1.6	0.03
			100	1,200	650	0.15	1.3	1,200	650	0.15	1.3	1,200	500	0.18	1.6	0.03
10	R2	0.5°	120	1,000	550	0.1	1.3	1,000	550	0.1	1.3	1,000	450	0.18	1.6	0.03
			35	3,800	2,100	0.5	2.5	2,400	1,000	0.3	1.6	3,800	1,500	0.2	2.4	0.1
			50	3,100	1,950	0.4	2.4	2,400	1,000	0.3	1.6	3,100	1,200	0.2	2.4	0.1
			60	2,500	1,750	0.27	2	2,400	1,000	0.27	1.6	2,500	1,000	0.2	2.4	0.1
			70	2,200	1,350	0.2	2	2,200	900	0.2	1.6	2,200	900	0.2	2.4	0.07
			80	1,500	900	0.19	2	1,500	680	0.19	1.6	1,500	600	0.2	2.4	0.07
			100	1,200	720	0.16	2	1,200	550	0.16	1.6	1,200	450	0.2	2.4	0.05
12	R2	0.5°	120	1,050	650	0.13	2	1,000	500	0.13	1.6	1,050	400	0.2	2.4	0.05
			140	850	550	0.1	1.5	800	450	0.1	1.4	850	350	0.2	2.4	0.03
			160	700	500	0.07	1.5	700	400	0.07	1.4	700	300	0.2	2.4	0.03
			45	3,200	2,200	0.6	3.4	2,000	840	0.3	1.6	3,200	1,500	0.24	3.2	0.15
			60	2,500	2,100	0.5	3.2	2,000	840	0.3	1.6	2,500	1,200	0.24	3.2	0.15
			70	2,100	1,900	0.4	2.8	2,000	840	0.28	1.6	2,100	1,000	0.24	3.2	0.1
			85	1,800	1,500	0.3	2.7	1,500	630	0.22	1.6	1,800	870	0.24	3.2	0.1
16	R3	0.5°	100	1,300	1,000	0.2	2.6	1,200	500	0.2	1.6	1,300	630	0.24	3.2	0.1
			120	1,000	700	0.15	2.5	1,000	500	0.15	1.6	1,000	480	0.24	3.2	0.05
			140	900	600	0.15	2	900	400	0.1	1.6	900	440	0.24	3.2	0.05
			160	700	500	0.1	2	700	400	0.1	1.6	700	380	0.24	3.2	0.05
			55	2,400	2,000	0.5	4.2	1,500	630	0.3	1.6	2,400	1,350	0.3	4	0.2
20	R3	0.5°	80	1,900	1,900	0.47	4	1,500	630	0.3	1.6	1,900	1,100	0.3	4	0.15
			90	1,600	1,700	0.4	3.4	1,500	630	0.3	1.6	1,600	900	0.3	4	0.1
			105	1,400	1,300	0.29	3.3	1,400	580	0.28	1.6	1,400	800	0.3	4	0.07
			120	1,000	850	0.2	3.2	1,000	450	0.2	1.6	1,000	600	0.3	4	0.05
20	R3	0.5°	70	1,900	2,000	0.5	5.5	1,200	500	0.3	1.6	1,900	1,550	0.42	5.5	0.2
			90	1,500	1,900	0.47	5.3	1,200	500	0.3	1.6	1,500	1,200	0.42	5.5	0.15
			110	1,300	1,700	0.42	4.2	1,200	500	0.3	1.6	1,300	1,050	0.42	5.5	0.1
			130	1,100	1,300	0.31	3.8	1,100	450	0.3	1.6	1,100	900	0.42	5.5	0.07
			150	760	870	0.25	3.4	760	350	0.23	1.6	760	600	0.42	5.5	0.05

- 上記の突き出し長別条件は目安です。実際の加工条件に合わせて調節して下さい。
- 機械、ホルダは剛性の高いものをご使用下さい。
- 工具の振れ精度を最小限に抑えてご使用下さい。
- 切削油剤は被削材に適したもので、発煙性の少ないものを選定して下さい。通常エアブローを推奨致します。
- 走査線加工を行う場合は、 a_e の数値を使用せずに、 a_p の数値を参考にご使用下さい。
- CAMや機械側でコーナ部のR挿入もしくは減速を設定することで、より安定した高送り加工が可能となります。
- コーナ部等切削負荷が変動する場合や加工精度を要求される場合には、回転速度を抑えてご使用下さい。
- 推奨傾斜切込み角度以上で加工される場合には、送り速度を下げてご使用下さい。
- PHX-PC-DFRは、P4の表を目安に工具突き出し長さを計算し、切削条件を設定して下さい。

- The above mentioned conditions according to projection lengths are intended as general guidelines for reference only. Adjustments should be made based on actual milling conditions.
- Highly rigid machines and tool holders should be used.
- Tool vibrations should be kept at a minimum level for maximum accuracy.
- Use a suitable cutting fluid with high smoke retardant properties.
- In the case of linear machining, do not use the a_e value, instead refer to the a_p value.
- More stable high-feed machining in the corners can be attained by setting an R insertion or deceleration on the CAM or machine side.
- When cutting load fluctuates (in the corners, etc.) or when high precision is required, be sure to control the rotational speed.
- When cutting at greater than the recommended cutting angle, reduce the feed.
- For the PHX-PC-DFR, please set the cutting condition by using the table on Page 4 to calculate the overhang length.

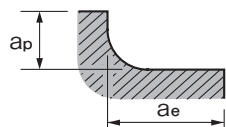

PHX-DBT/PHX-LN-DBT/PHX-PC-DBT 切削条件基準表 Recommended Milling Conditions

下記は代表的な材質を掲載しております。その他の材質につきましては、当社HPの「技術情報」を参照下さい。

Below is a sampling of materials. For other materials, please refer to the "Technical Information" section of our Web site.

被削材 WORK MATERIAL		快削材 高効率荒取り条件 ~38HRC Free-machining materials Cutting conditions for high efficiency roughing				高じん性金型材 中荒取り条件 38~53HRC High toughness mold materials Cutting conditions for semi-roughing (びびり抑制条件) Vibration control conditions				溝加工条件 ~53HRC Cutting conditions for slotting (びびり抑制条件) Vibration control conditions				仕上げ加工条件 ~55HRC Machining conditions for finishing (びびり抑制条件) Vibration control conditions							
		調質鋼・プリハードン鋼 HARDENED STEELS · PREHARDENED STEELS																			
		SKT4 · SKD61 · NAK80 · HPM1 · DH**				DH** · DAC55				SKT4 · SKD61 · NAK80 · HPM1 · DH**				SKT4 · SKD61 · NAK80 · HPM1 · DH**							
R	突き出し量 L/D	推奨傾斜 切込角度 Recommended Cutting Angle	回転速度 SPEED (min ⁻¹)		送り速度 FEED (mm/min)		切込深さ(mm) DEPTH OF CUT		回転速度 SPEED (min ⁻¹)		送り速度 FEED (mm/min)		切込深さ(mm) DEPTH OF CUT		回転速度 SPEED (min ⁻¹)		送り速度 FEED (mm/min)		切込深さ(mm) DEPTH OF CUT		仕上げ代 (mm) CLEARANCE
			ap	Pf	ap	Pf	ap	Pf	ap	Pf	ap	Pf	ap	Pf	ap	Pf					
R0.5	6	0.3°	18,000	1,000	0.05	0.16	18,000	900	0.05	0.16	18,000	280	0.007	0.03	18,000	1,200	0.03	0.03	0.05		
	10		16,000	800	0.04	0.16	16,000	800	0.04	0.16	16,000	120	0.003	0.3	16,000	1,000	0.03	0.03	0.03		
	15		8,000	420	0.03	0.16	8,000	420	0.03	0.16	-	-	-	-	8,000	500	0.03	0.03	0.03		
	20		6,000	300	0.02	0.12	6,000	300	0.02	0.12	-	-	-	-	6,000	380	0.03	0.03	0.03		
	25		6,000	130	0.02	0.08	6,000	130	0.02	0.08	-	-	-	-	6,000	350	0.03	0.03	0.03		
30	6,000	90	0.01	0.05	6,000	90	0.01	0.05	-	-	-	-	6,000	250	0.03	0.03	0.03				
R0.75	6	0.3°	18,000	1,500	0.1	0.3	16,000	1,300	0.1	0.3	16,000	650	0.07	0.15	18,000	1,100	0.04	0.04	0.05		
	10		15,000	1,100	0.06	0.25	15,000	950	0.06	0.25	15,000	320	0.01	0.1	15,000	900	0.04	0.04	0.03		
	16		7,500	230	0.02	0.2	7,500	200	0.02	0.2	7,500	300	0.007	0.05	7,500	450	0.04	0.04	0.03		
R1	6	0.3°	18,000	1,600	0.2	0.6	15,000	1,400	0.2	0.4	12,000	600	0.15	0.15	15,000	1,800	0.06	0.05	0.1		
	10		12,000	1,250	0.14	0.4	12,000	1,100	0.14	0.4	12,000	600	0.1	0.05	12,000	1,500	0.06	0.05	0.07		
	15		7,800	820	0.14	0.4	7,800	780	0.14	0.4	7,800	450	0.07	0.05	7,800	980	0.06	0.05	0.07		
	20		6,200	650	0.13	0.4	6,200	600	0.13	0.3	6,200	340	0.05	0.05	6,200	600	0.06	0.05	0.05		
	25		4,700	500	0.12	0.3	4,700	500	0.12	0.3	-	-	-	-	4,700	450	0.06	0.05	0.05		
	30		3,500	400	0.1	0.3	3,500	400	0.1	0.3	-	-	-	-	3,500	450	0.06	0.05	0.05		
	35		3,500	400	0.07	0.3	3,500	400	0.07	0.3	-	-	-	-	3,500	450	0.06	0.05	0.03		
	40		3,500	300	0.07	0.25	3,500	300	0.07	0.25	-	-	-	-	3,500	450	0.06	0.05	0.03		
	45		3,500	200	0.07	0.2	3,500	200	0.07	0.2	-	-	-	-	3,500	450	0.06	0.05	0.03		
	50		3,500	150	0.06	0.1	3,500	150	0.06	0.1	-	-	-	-	3,500	450	0.06	0.05	0.03		
60	3,500	150	0.05	0.1	3,500	150	0.05	0.1	-	-	-	-	3,500	450	0.06	0.05	0.03				
R1.5	10	0.3°	12,000	1,900	0.21	0.5	8,000	1,200	0.21	0.5	8,000	700	0.13	0.1	11,000	2,050	0.09	0.08	0.1		
	15		10,000	1,550	0.2	0.5	8,000	1,200	0.2	0.5	8,000	550	0.1	0.1	10,000	1,900	0.09	0.08	0.07		
	20		7,500	1,150	0.19	0.5	7,200	1,100	0.19	0.5	7,200	480	0.06	0.07	7,500	1,400	0.09	0.08	0.07		
	25		4,800	750	0.19	0.5	4,600	700	0.19	0.5	4,600	320	0.04	0.05	4,800	900	0.09	0.08	0.05		
	30		4,000	630	0.16	0.4	3,400	500	0.16	0.4	3,400	240	0.02	0.03	3,800	720	0.09	0.08	0.03		
	40		2,800	440	0.13	0.4	2,600	400	0.13	0.4	-	-	-	-	2,600	500	0.09	0.08	0.03		
	50		2,200	350	0.1	0.4	2,200	300	0.1	0.4	-	-	-	-	2,200	400	0.09	0.08	0.03		
60	2,200	350	0.07	0.4	2,200	300	0.07	0.4	-	-	-	-	2,200	400	0.09	0.08	0.03				
R2	10	0.5°	9,600	2,000	0.3	0.6	6,000	1,250	0.3	0.6	6,000	800	0.15	0.1	9,500	2,400	0.12	0.1	0.1		
	15		9,300	1,900	0.27	0.6	6,000	1,200	0.27	0.6	6,000	800	0.12	0.1	9,000	2,250	0.12	0.1	0.1		
	20		7,600	1,550	0.25	0.6	6,000	1,150	0.25	0.6	6,000	700	0.1	0.07	8,200	2,050	0.12	0.1	0.1		
	25		6,100	1,250	0.23	0.6	5,500	1,100	0.23	0.6	5,500	450	0.05	0.07	5,500	1,350	0.12	0.1	0.07		
	30		5,000	1,050	0.2	0.6	4,500	800	0.2	0.6	4,500	350	0.03	0.05	4,500	1,100	0.12	0.1	0.07		
	35		3,600	750	0.16	0.5	3,600	650	0.16	0.5	3,600	280	0.01	0.03	3,600	900	0.12	0.1	0.05		
	40		3,000	630	0.12	0.5	3,000	550	0.12	0.5	3,000	150	0.007	0.01	3,000	750	0.12	0.1	0.05		
	45		2,700	550	0.1	0.4	2,700	500	0.1	0.4	-	-	-	-	2,700	680	0.12	0.1	0.03		
	50		2,500	520	0.1	0.4	2,500	450	0.1	0.4	-	-	-	-	2,500	630	0.12	0.1	0.03		
60	2,100	430	0.08	0.4	2,100	400	0.08	0.4	-	-	-	-	2,100	530	0.12	0.1	0.03				
R2.5	10	0.5°	7,700	1,900	0.35	0.8	4,800	1,100	0.35	0.8	4,800	900	0.2	0.1	7,700	2,400	0.15	1.2	0.1		
	15		7,700	1,900	0.3	0.8	4,800	1,000	0.3	0.8	4,800	850	0.16	0.1	6,100	1,900	0.15	1.2	0.1		
	20		7,700	1,800	0.3	0.8	4,800	950	0.3	0.8	4,800	700	0.12	0.07	6,100	1,900	0.15	1.2	0.1		
	25		5,100	1,300	0.25	0.8	4,800	900	0.25	0.8	4,800	650	0.06	0.05	5,100	1,600	0.15	1.2	0.07		
	30		5,100	1,200	0.2	0.6	4,800	850	0.2	0.6	4,800	500	0.03	0.05	5,100	1,600	0.15	1.2	0.07		
	35		4,400	1,100	0.14	0.6	4,400	750	0.14	0.6	4,400	400	0.015	0.03	4,400	1,350	0.15	1.2	0.05		
40	3,100	750	0.1	0.6	3,100	650	0.1	0.6	3,100	260	0.007	0.03	3,100	950	0.15	1.2	0.05				
R3	24	0.5°	6,400	1,900	0.43	1.2	4,000	1,200	0.3	1	4,000	900	0.3	0.1	6,500	1,450	0.18	0.16	0.1		
	30		5,100	1,500	0.34	1.2	4,000	1,150	0.3	1	4,000	900	0.25	0.1	5,100	1,950	0.18	0.16	0.1		
	36		4,200	1,250	0.38	1.2	4,000	1,100	0.3	1	4,000	750	0.2	0.07	4,200	1,580	0.18	0.16	0.07		
	42		3,700	1,050	0.2	0.9	3,700	1,000	0.2	1	3,700	500	0.15	0.05	3,700	1,400	0.18	0.16	0.07		
	48		3,600	750	0.15	0.9	2,600	700	0.15	0.8	2,600	400	0.1	0.03	2,600	980	0.18	0.16	0.05		
	54		2,100	630	0.1	0.8	2,100	600	0.1	0.8	2,100	240	0.05	0.03	2,100	800	0.18	0.16	0.05		
	66		1,900	550	0.08	0.7	1,900	500	0.08	0.7	-	-	-	-	1,900	700	0.18	0.16	0.03		
	80		1,700	450	0.08	0.6	1,700	400	0.08	0.6	-	-	-	-	1,700	650	0.18	0.16	0.03		

ディープフィードボールノーズシリーズ



次ページへ



前ページより

被削材 WORK MATERIAL		快削材 高能率荒取り条件 ~38HRC Free-machining materials Cutting conditions for high efficiency roughing				高じん性金型材 中荒取り条件 38~53HRC High toughness mold materials Cutting conditions for semi-roughing (びびり抑制条件) Vibration control conditions				溝加工条件 ~53HRC Cutting conditions for slotting (びびり抑制条件) Vibration control conditions				仕上げ加工条件 ~55HRC Machining conditions for finishing (びびり抑制条件) Vibration control conditions					
		調質鋼・プリハードン鋼 HARDENED STEELS · PREHARDENED STEELS																	
		SKT4 · SKD61 · NAK80 · HPM1 · DH**				DH** · DAC55				SKT4 · SKD61 · NAK80 · HPM1 · DH**				SKT4 · SKD61 · NAK80 · HPM1 · DH**					
R	突き出し 量 L/D	推奨傾斜 切込角度 Recommended Cutting Angle	回転速度 SPEED (min ⁻¹)	送り速度 FEED (mm/min)	切込深さ(mm) DEPTH OF CUT		回転速度 SPEED (min ⁻¹)	送り速度 FEED (mm/min)	切込深さ(mm) DEPTH OF CUT		回転速度 SPEED (min ⁻¹)	送り速度 FEED (mm/min)	切込深さ(mm) DEPTH OF CUT		回転速度 SPEED (min ⁻¹)	送り速度 FEED (mm/min)	切込深さ(mm) DEPTH OF CUT		仕上げ代 (mm) CLEARANCE
					ap	Pf			ap	Pf			ap	Pf			ap	Pf	
R4	30	0.5°	4,800	2,300	0.45	1.5	3,000	1,260	0.3	1.5	3,000	1,050	0.3	0.15	4,800	2,400	0.24	0.21	0.1
	40		3,800	1,800	0.38	1.3	3,000	1,200	0.3	1.3	3,000	1,050	0.3	0.1	3,800	1,900	0.24	0.21	0.1
	48		3,200	1,500	0.28	1.2	3,000	1,100	0.25	1.2	3,000	900	0.25	0.1	3,200	1,600	0.24	0.21	0.07
	56		2,700	1,300	0.2	1.1	2,700	1,000	0.2	1.1	2,700	800	0.2	0.07	2,700	1,350	0.24	0.21	0.07
	64		1,900	900	0.2	1	1,900	700	0.17	1	1,900	500	0.17	0.07	1,900	950	0.24	0.21	0.05
	80		1,500	700	0.15	0.8	1,500	550	0.14	0.8	-	-	-	-	1,500	750	0.24	0.21	0.03
	100		1,200	600	0.15	0.8	1,200	400	0.1	0.8	-	-	-	-	1,200	600	0.24	0.21	0.03
R5	35	0.5°	3,800	2,300	0.65	1.8	2,400	1,000	0.4	1.6	2,400	850	0.4	0.15	3,800	2,400	0.3	0.27	0.1
	50		3,100	1,900	0.55	1.8	2,400	1,000	0.3	1.6	2,400	850	0.3	0.15	3,100	1,950	0.3	0.27	0.1
	60		2,500	1,500	0.46	1.6	2,400	1,000	0.3	1.5	2,400	850	0.3	0.1	2,500	1,550	0.3	0.27	0.1
	70		2,200	1,300	0.34	1.6	2,200	900	0.3	1.5	2,200	800	0.3	0.1	2,200	1,350	0.3	0.27	0.07
	80		1,500	800	0.24	1.6	1,500	600	0.2	1.5	1,500	600	0.2	0.07	1,500	950	0.3	0.27	0.07
	100		1,200	600	0.15	1.5	1,200	500	0.12	1.5	1,200	500	0.12	0.07	1,200	750	0.3	0.27	0.05
	120		1,050	500	0.1	1.3	1,000	400	0.1	1.3	-	-	-	-	1,050	650	0.3	0.27	0.05
R6	45	0.5°	3,200	1,700	0.8	2	2,000	800	0.8	1.8	2,000	800	0.6	0.15	3,200	2,400	0.36	0.32	0.15
	60		2,500	1,300	0.65	2	2,000	800	0.65	1.8	2,000	800	0.5	0.15	2,500	1,900	0.36	0.32	0.15
	70		2,100	1,100	0.57	2	2,000	800	0.57	1.8	2,000	800	0.5	0.1	2,100	1,600	0.36	0.32	0.1
	85		1,800	950	0.42	1.8	1,500	600	0.42	1.7	1,500	600	0.4	0.1	1,800	1,350	0.36	0.32	0.1
	100		1,300	690	0.3	1.8	1,200	500	0.3	1.7	1,200	500	0.3	0.1	1,300	980	0.36	0.32	0.1
	120		1,000	530	0.25	1.5	1,000	420	0.25	1.5	-	-	-	-	1,000	750	0.36	0.32	0.05
	140		900	470	0.2	1.5	900	380	0.2	1.5	-	-	-	-	900	680	0.36	0.32	0.05
R8	55	0.5°	2,400	1,600	1	2.2	1,500	600	1	1.8	1,500	600	0.8	0.15	2,400	2,400	0.48	0.4	0.2
	80		1,900	1,250	0.9	2.2	1,500	600	0.9	1.8	1,500	600	0.8	0.15	1,900	1,900	0.48	0.4	0.15
	90		1,600	1,050	0.75	2.2	1,500	600	0.75	1.8	1,500	600	0.7	0.1	1,600	1,600	0.48	0.4	0.1
	105		1,400	900	0.55	2	1,400	570	0.55	1.7	1,400	570	0.5	0.07	1,400	1,400	0.48	0.4	0.07
	120		1,000	650	0.4	2	1,000	420	0.4	1.7	1,000	420	0.4	0.05	1,000	1,000	0.48	0.4	0.05
R10	70	0.5°	1,900	1,500	1.2	3.6	1,200	500	1.2	1.8	1,200	500	0.8	0.15	1,900	2,400	0.6	0.5	0.2
	90		1,500	1,200	1.1	3.6	1,200	500	1.1	1.8	1,200	500	0.8	0.15	1,500	1,900	0.6	0.5	0.15
	110		1,300	1,000	0.9	3.5	1,200	500	0.9	1.8	1,200	500	0.8	0.1	1,300	1,600	0.6	0.5	0.1
	130		1,100	850	0.7	3.4	1,100	450	0.7	1.8	1,100	450	0.7	0.1	1,100	1,400	0.6	0.5	0.07
	150		760	600	0.5	3.3	760	320	0.5	1.8	760	320	0.5	0.07	760	950	0.6	0.5	0.05

- 上記の突き出し量別条件は目安です。実際の加工条件に合わせて調節して下さい。
- R0.5~R2.5までは標準状態での首元でチャッキングした工具突き出し加工条件です。
- 機械、ホルダは剛性の高いものをご使用下さい。
- 工具の振れ精度を最小限に抑えてご使用下さい。
- 走査線加工を行う場合は、Pfの数値を使用せずに、apの数値を参考にご使用下さい。
- CAMや機械側でコーナ部のR挿入もしくは減速を設定することで、より安定した高送り加工が可能となります。
- コーナ部等切削負荷が変動する場合や加工精度を要求される場合には、回転速度を抑えてご使用下さい。
- 推奨傾斜切込み角度以上で加工される場合には、送り速度を下げてご使用下さい。
- PHX-PC-DBTは、P.4の表を目安に工具突き出し長さを計算し、切削条件を設定して下さい。

- The above mentioned conditions according to projection lengths are intended as general guidelines for reference only. Adjustments should be made based on actual milling conditions.
- For 0.5R-2.5R, the machining conditions are based on chucking the tool up to the base of the neck.
- Highly rigid machines and tool holders should be used.
- Tool vibrations should be kept at a minimum level for maximum accuracy.
- In the case of linear machining, do not use the Pf value, instead refer to the ap value.
- More stable high-feed machining in the corners can be attained by setting an R insertion or deceleration on the CAM or machine side.
- When cutting load fluctuates (in the corners, etc.) or when high precision is required, be sure to control the rotational speed.
- When cutting at greater than the recommended cutting angle, reduce the feed.
- For the PHX-PC-DBT, please set the cutting condition by using the table on Page 4 to calculate the overhang length.

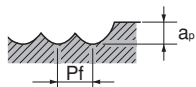

ボールエンドミルをご使用の場合は、ラジウスエンドミルと比較して前カッタパスにおける削り残しが多いため、荒・仕上げ加工の2回に分けて等高線加工することによってリブ溝の精度を上げることが出来ます。
In case using ball nose endmills, it is highly recommended to use rough and finish on the same contour to improve the quality of ribs.

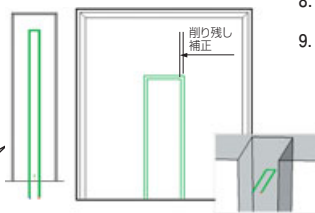

Deep-Feed Ball Nose Series
ダイヤブライダークォーパールシリーズ

PHX-LN-CRE 切削条件基準表 Recommended Milling Conditions

被削材 WORK MATERIAL			リブ溝切削 Lib flute milling								等高線仕上げ切削 Contour line finish cutting		
			溝 Slotting				等高オフセット Contour offset						
			CENA1, STAVAX, HPM38, SKD61 42~55HRC										
外径 Dc	r	首下長 ℓ2	回転速度 SPEED (min ⁻¹)	送り速度 FEED (mm/min)	切込深さ(mm) DEPTH OF CUT		回転速度 SPEED (min ⁻¹)	送り速度 FEED (mm/min)	切込深さ(mm) DEPTH OF CUT		回転速度 SPEED (min ⁻¹)	送り速度 FEED (mm/min)	切込深さ(mm) DEPTH OF CUT
					ap	ae			ap	ae			
0.8	0.1	2	18,000	720	0.02	0.2	18,000	930	0.02	0.2	18,000	1,150	0.015
		6	18,000	720	0.02	0.2	18,000	930	0.02	0.2	18,000	1,150	0.015
		4	18,000	720	0.02	0.2	18,000	930	0.02	0.2	18,000	1,150	0.015
		8	15,000	540	0.013	0.2	15,000	630	0.013	0.2	16,000	700	0.013
1	0.1	4	18,000	830	0.03	0.23	18,000	880	0.03	0.23	18,000	1,440	0.015
		6	18,000	830	0.024	0.23	18,000	880	0.024	0.23	18,000	1,440	0.015
		8	15,000	750	0.013	0.23	15,000	800	0.013	0.23	15,000	1,200	0.015
		10	12,000	300	0.007	0.2	12,000	400	0.007	0.2	12,000	960	0.015
		12	10,500	220	0.006	0.18	10,500	288	0.006	0.18	10,500	840	0.015
1	0.2	4	18,000	830	0.03	0.23	18,000	880	0.03	0.23	18,000	1,440	0.018
		6	18,000	830	0.024	0.23	18,000	880	0.024	0.23	18,000	1,440	0.018
		8	15,000	750	0.013	0.23	15,000	800	0.013	0.23	15,000	1,200	0.018
		10	12,000	300	0.007	0.2	12,000	400	0.007	0.2	12,000	960	0.018
1	0.3	4	18,000	830	0.03	0.23	18,000	1,000	0.03	0.23	18,000	1,440	0.022
		6	18,000	830	0.024	0.23	18,000	890	0.024	0.23	18,000	1,440	0.022
		4	16,000	1,230	0.03	0.34	16,000	1,300	0.03	0.34	18,000	1,620	0.015
		8	16,000	1,230	0.026	0.34	16,000	1,300	0.026	0.34	18,000	1,620	0.015
1.5	0.1	12	10,000	480	0.013	0.3	10,000	750	0.013	0.3	10,000	900	0.015
		4	16,000	1,230	0.03	0.34	16,000	1,300	0.03	0.34	18,000	1,620	0.018
		6	16,000	1,230	0.029	0.34	16,000	1,300	0.029	0.34	18,000	1,620	0.018
1.5	0.2	8	16,000	1,230	0.026	0.34	16,000	1,300	0.026	0.34	18,000	1,620	0.018
		8	12,000	1,300	0.03	0.46	12,000	1,760	0.03	0.46	18,000	1,620	0.015
		10	12,000	1,200	0.03	0.46	12,000	1,620	0.03	0.46	15,000	1,350	0.015
2	0.1	12	12,000	1,150	0.024	0.46	12,000	1,320	0.024	0.46	13,000	1,170	0.015
		16	7,600	780	0.012	0.46	7,600	750	0.012	0.46	7,000	630	0.015
		8	12,000	1,300	0.05	0.46	12,000	1,620	0.05	0.46	18,000	1,620	0.022
2	0.3	12	12,000	1,150	0.04	0.46	12,000	1,320	0.04	0.46	13,000	1,170	0.022
		6	12,000	1,300	0.08	0.45	12,000	1,760	0.08	0.45	18,000	1,620	0.025
2	0.5	8	12,000	1,300	0.075	0.45	12,000	1,760	0.075	0.45	18,000	1,620	0.025
		10	12,000	1,200	0.07	0.45	12,000	1,620	0.07	0.45	15,000	1,350	0.025
		12	12,000	1,150	0.06	0.45	12,000	1,320	0.06	0.45	13,000	1,170	0.025
		12	8,000	1,200	0.046	0.7	8,000	1,400	0.046	0.7	13,000	1,170	0.022

- 加工形状、機械剛性、ホルダ剛性、ワーク保持力等の使用状況により、回転速度、送り速度、切込深さを調節下さい。
- 回転速度、送り速度が機械性能によって上がらない場合は、回転速度、送り速度を同じ比率で下げてご使用下さい。
- 高い切削速度や高い送り速度は、工具の消耗や加工精度を落とす原因となります。必要に応じて送り速度を下げてご使用下さい。
- 加工形状によって加工時にビビリが発生する場合は、形状の食い込みなどの原因となる為、回転速度と送り速度を同じ比率で下げて調節しご使用下さい。
- 精密、精細加工は静粛性に優れた専用加工機をご使用下さい。
- 加工時は工具刃先の振れを0.005mm以下に抑えてご使用下さい。
- 仕上げ加工の高効率加工を行う場合、回転速度、送り速度は2倍を上限に調節下さい。
- 平面上を仕上げる場合は、機械の振動が少ない回転域で使用し、送り速度による機械のブレが起らないように加工下さい。
- 工具コーナ半径で曲面形状の仕上げ加工を行う場合は、加工ピッチ(カスプハイトを考慮した)を変えてご使用下さい。
- 傾斜切り込み角度は、0.3°~0.5°を目安に設定して下さい。

- Adjust the speed, feed, and plunge depth in accordance with operating conditions, including the machining shape, machine rigidity, holder rigidity, and workholding force.
- If the speed and feed rates cannot increase due to equipment performance, operate by reducing the speed and feed rates at the same ratio.
- High cutting speeds and feed rates can cause cutter wear or reduce machining precision. Therefore, operate by reducing the feed rate as needed.
- Depending on the shape to be machined, if the end mill chatters during machining, it can bite into the shape. Therefore, operate by reducing the speed and feed rates at the same ratio.
- For precise, detailed machining, use a dedicated machine that operates quietly.
- Operate by keeping the runout at the tip of the end mill below 0.005mm.
- To perform finish machining with a high level of efficiency, keep the speed and feed rates below 2 times.
- To finish a flat surface, operate at a speed range with a minimal amount of equipment vibration, making sure that the feed rate does not cause the equipment to wobble.
- To finish machine a curved surface using the corner radius of the tool, operate by changing the machining pitch.
- Set the inclined cut angle approximately between 0.3° and 0.5°



同時5軸加工事例 Example in five-axis machining

WORK SIZE 117×100×50mm
PX30 40HRC



被削材質：PX30 40HRC 使用機械：5軸加工機 主軸タイプ：HSK A63タイプ 最高回転数：18,000min⁻¹
Work Material Machine Main spindle Maximum RPM

工程番号 Process	加工内容 Milling process	使用工具 Tool	突き出し量 Projection Length	残り代 Remnants	回転速度 (min ⁻¹) Speed	送り速度 (mm/min) Feed	軸方向 切込深さ (mm) Ƴp	径方向 切込深さ (mm) Ƴe, pf	ホルダ Holder	クーラント Coolant	切削距離 (m) Milling Length	切削時間 Cutting Time
1	上面湾曲部同時5軸荒取り Five-axis cavity roughing of upper contour areas	SI-WC-RESF 12	30	0.1	5,300	2,200	1~8	8.4	焼きばめホルダ Shrink fit holder	エアブロー Air blow	4.71	0:02:09
2	キャビ部等高線荒取り Contour cavity roughing	PHX-CRT 10×R2	30	0.1	6,000	6,000	0.5	4	焼きばめホルダ Shrink fit holder	エアブロー Air blow	15.74	0:02:47
3	キャビ部同時5軸高線荒取り Five-axis contour cavity roughing	PHX-LN-DBT R3×20	30	0.1	8,000	4,500	0.5	1.5	焼きばめホルダ Shrink fit holder	エアブロー Air blow	36.8	0:08:11
4	キャビ部同時5軸走査線加工 Five-axis linear cavity milling	↓	↓	0.08	↓	↓	-	0.3	↓	↓	6.96	0:01:33
5	キャビ部同時5軸等高線仕上げ Five-axis contour cavity finishing	PHX-LN-DBT R3×20	30	0	8,000	1,650	0.2	-	焼きばめホルダ Shrink fit holder	エアブロー Air blow	34.75	0:21:03
6	キャビ部割り出し走査線仕上げ Linear cavity finishing	↓	↓	↓	↓	↓	-	0.18	↓	↓	14.82	0:08:59
7	キャビ部同時5軸走査線仕上げ Five-axis linear cavity finishing	↓	↓	↓	↓	↓	-	↓	↓	↓	1.187	0:01:07
8	キャビ部割り出し走査線仕上げ Linear cavity finishing	↓	↓	↓	↓	↓	-	↓	↓	↓	8.69	0:05:16
9	上面湾曲部割り出し走査線仕上げ Linear cavity finishing of upper contour areas	↓	↓	↓	↓	↓	-	↓	↓	↓	31.64	0:19:11
10	キャビ部隅部取り残り加工 Cavity milling of corner areas	PHX-LN-DBT R1×12	16	0	15,000	1,200	0.15	0.15	焼きばめホルダ Shrink fit holder	エアブロー Air blow	22.66	0:18:53

トータル加工時間 01:29:09
Total operation time

第7弾 OSG Phoenix シリーズを ご期待ください

Please be on the lookout for the seventh round of the OSG Phoenix Series

To be continued...



ツール コミュニケーション

本社 〒442-8543 愛知県豊川市本野ヶ原3-22 ☎(0533)82-1111 FAX(0533)82-1131
 東部営業部 〒143-0025 東京都大田区南馬込3-25-4 ☎(03)5709-4501 FAX(03)5709-4515
 中部営業部 〒465-0058 名古屋市名東区貴船1-9 ☎(052)703-6131 FAX(052)703-7775
 西部営業部 〒550-0013 大阪市西区新町2-18-2 ☎(06)6538-3880 FAX(06)6538-3879

仙台 ☎(022)390-9701	厚木 ☎(046)296-1380	岡山 ☎(086)241-0411
郡山 ☎(024)991-7485	静岡 ☎(054)283-6651	四国 ☎(087)868-4003
新潟 ☎(025)286-9503	浜松 ☎(053)461-1121	広島 ☎(082)507-1227
上田 ☎(0268)28-7381	豊川 ☎(0533)92-1501	九州 ☎(092)504-1211
諏訪 ☎(0266)58-0152	安城 ☎(0566)77-2366	北九州 ☎(093)435-3655
両毛 ☎(0270)40-5855	名古屋 ☎(052)703-6131	熊本 ☎(096)386-5120
宇都宮 ☎(028)651-2720	岐阜 ☎(058)259-6055	東部GST ☎(03)5709-4501
八王子 ☎(042)645-5406	金沢 ☎(076)268-0830	中部GST ☎(052)703-6131
川口 ☎(048)294-3951	京滋 ☎(077)553-2012	西部GST ☎(06)6538-3880
茨城 ☎(029)354-7017	大阪 ☎(06)6747-7041	
東京 ☎(03)5709-4501	明石 ☎(078)927-8212	

〈工具の技術的なご相談は…〉
0120-41-5981
 コミュニケーションダイヤル 9:00~12:00 / 13:00~17:00 土日祝日を除く
 コミュニケーションFAX 0533-82-1134 コミュニケーションE-mail hp-info@osg.co.jp

OSG E-mail倶楽部 無料メールマガジン
 E-mailで最新情報をお届けします。
 入会窓口は <https://www.osg.co.jp/support/club/index.php>
 〈その他のご相談は…〉 E-mail:cs-info@osg.co.jp

OSG 検索 www.osg.co.jp



安全にお使いいただくために

- 工具を使用する時は、破損する危険があるので、必ずカバー・保護メガネ・安全靴等を使用して下さい。
- 異常音・異常振動が発生したら、直ちに使用を中止して下さい。
- 切れ刃は素手でさわらないで下さい。
- 工具には手を加えないで下さい。
- 切りくずは素手でさわらないで下さい。
- 加工前に工具の寸法確認を行って下さい。
- 工具の切れ味が悪くなったら使用を中止して下さい。



Safe use of cutting tools

- Use safety cover, safety glasses and safety shoes during operation.
- Do not touch cutting edges with bare hands.
- Do not touch cutting chips with bare hands. Chips will be hot after cutting.
- Stop cutting when the tool becomes dull.
- Stop cutting operation immediately if you hear any strange cutting sounds.
- Do not modify tools.
- Please use correct tools for the operation. Check dimensions to ensure proper selection.

◆ 製品については、常に研究・改良を行っておりますので、予告なく本カタログ掲載仕様を変更する場合があります。

◆ Tool specifications subject to change without notice.



OSG CORPORATION

3-22 Honnogahara, Toyokawa, Aichi 442-8543 Japan
 Tel. +81-533-82-1118 Fax. +81-533-82-1136
 E-mail:cs-info@osg.co.jp

OSG 代理店

※本書掲載内容の無断転載・複製を禁じます。 ※ All rights reserved. © OSG CORPORATION.2012



このカタログの印刷には、
環境に配慮した植物油・インキ
を使用しております。

N-72.210.BA.BCD(DN)
12.10